

# HUNTER EDUCATION HANDBOOK

## R-LICENCE ACCREDITATION COURSE



# NEW SOUTH WALES R-LICENCE ACCREDITATION COURSE

## CONTENTS

### Section 1: Mandatory training

Unit 1: Introduction to hunting in NSW .....	3
Unit 2: Hunting laws in NSW .....	10
Unit 3: Being ethical & involved .....	20
Unit 4: Animal ID, wildlife and welfare .....	25
Unit 5: Hunting on public land .....	37
Unit 6: Hunting on private land .....	56
Unit 7: Outdoor safety & survival .....	67
Unit 8: Being a safe hunter .....	76
Unit 9: Hunting techniques .....	84

### Section 2: R-Licence categories

Category 1: Hunting with firearms .....	89
Category 2: Hunting with bows .....	120
Category 3: Hunting with dogs .....	136



# SECTION 1: MANDATORY TRAINING

## UNIT 1: INTRODUCTION TO HUNTING IN NSW



### Introduction to the course

Welcome to the NSW Online R-Licence Accreditation Course!

New South Wales (NSW) has many hunting opportunities offered through a regulated public land hunting program that is administered by DPI Hunting (part of the NSW Department of Primary Industries).

Public land hunting is managed by a licensing and regulatory system that ensures activities are conducted safely and ethically and provide a strong contribution to the NSW community.

To hunt on public land, hunters must first hold a valid NSW restricted game hunting licence, known as an R-Licence. This licence is available for adults and minors between the ages of 12 and 18 years.

To apply for an R-Licence, you must successfully complete this course and be a member of an Approved Hunting Organisation (AHO).

Licensed hunters can then use the online booking system, accessed through the NSW DPI website, to book a hunt on any of the declared public land forests open to hunting.

### About the course

The unit objectives are:

- understand the benefits of holding an R-Licence
- know who is responsible for regulating hunting in NSW
- know the goals of hunter education
- explain what Hunter LEAP is
- know what NSW game hunting licence fees are used for.



## Topics and categories

This course has been divided into two sections:

### Compulsory learning – NSW Hunter Education program:

This section contains compulsory learning that will give you the basic knowledge to become a safe, ethical and responsible hunter.

It covers the following topics:

- hunting laws in NSW
- being an ethical and involved hunter
- animals, identification and welfare
- hunting on public land
- hunting on private land
- outdoor safety and survival
- being a safe hunter
- hunting techniques.

**R-Licence categories:** There are three hunting methods permitted to be used when hunting on public land in NSW:

- firearms (rifles, shotguns and blackpowder firearms)
- bows
- dogs.

These methods are referred to as 'R-Licence categories'. To use any of these hunting methods on public land, you must first become accredited for the relevant category by completing the training module in this course.

When you pass the training module for each category, you will receive an R-Licence accreditation form, qualifying you to apply to DPI to use that method of hunting on public land. For example, if you don't have the Dogs category on your R-Licence, you cannot hunt with dogs on public land in NSW.

---

Important! Even if your R-Licence is endorsed with the firearm category, you cannot use a firearm unless you also hold a NSW firearms licence issued by the NSW Police Force Firearms Registry or equivalent issued by the relevant authority for the state in which you reside.

---

## Types and benefits of R-Licences



Holders of an R-Licence have the benefit of hunting any species listed in the *Game and Feral Animal Control Act 2002* (the Act) on public land in NSW that is declared and open for hunting (please check your Written permission for species that can be hunted in the selected forest.)

There are three different types of R-Licences that you can apply for depending on your type of hunting activity.

### 1. Standard – R-Licence

Recreational hunting on public or private land

### 2. Hunting guide – R-Guide

Guiding others in their hunt for fee or reward on public or private land; includes the authority of a Standard R-Licence

### 3. Commercial hunter – R-Commercial

Hunting on public or private land to sell part(s) of the harvested animal; includes the authority of a Standard R-Licence

R-Licence holders have access to public land hunting opportunities, native game bird hunting and other game and pest animal management programs on some private land.

Other benefits include:

- public liability insurance
- access to public land declared for hunting
- opportunity to take part in the Native Game Bird Management Program (additional training requirements apply)
- access to specialised hunter education and training opportunities through the Hunter LEAP (Learning, Education and Accreditation Program)
- access to safety and awareness initiatives such as GunSmart, Don't wing it: Be an effective game bird hunter and the Hunt

safe, hunt legal: Be a responsible pig dogger Program

- a peer network of responsible, ethical and safe hunters
- endorsement and international recognition by the International Hunter Education Association-USA (IHEA-USA)
- satisfying the recreational hunting/vermin control genuine reason criteria when applying for NSW firearms licence.

## Applying for a NSW Restricted Game Hunting Licence

To apply for an R-Licence, you must first successfully complete this course by:

- studying the online course material or the New South Wales Hunter Education Handbook
- completing each end-of-unit quiz
- achieving 100% in the Section 1 assessment
- achieving 100% in each of the R-Licence category assessment you choose to complete in Section 2.

If you do not achieve the pass mark of 100% on your first attempt for each of the assessments, you will be given a second attempt.



When you have successfully completed the course, you will receive an R-Licence Accreditation Certificate that you can save to your computer or print. You need to attach your R-Licence Accreditation Certificate to your R-Licence application.

When applying for an R-Licence, you also need to provide proof of membership with a NSW DPI Approved Hunting Organisation (AHO). A list of AHOs can be found on the DPI Hunting website.

You can apply for an R-Licence online or by completing an application form and mailing it to DPI Hunting. (More information about applying for an R-Licence can be found on the DPI Hunting website.)

## What is adequate training?

Hunters should be competent and possess the necessary skills required to be safe and responsible when undertaking any form of hunting. These skills are gained and developed through effective training programs.

To be granted an R-Licence, you must have completed a form of adequate training as specified in Clause 10 of the Regulation 2022. The R-Licence Accreditation Course satisfies the adequate training requirements to grant a NSW R-Licence.

Formal training is just the first step in understanding the obligations of holding any type of licence. Consistent learning and practice will help you achieve and maintain the necessary level of competency.



## Approved Hunting Organisations

An Approved Hunting Organisation is a hunting club or organisation that has received the ‘approved’ status from NSW DPI for the purpose of qualifying their members for an R-Licence.

To seek DPI approval, AHOs must have a constitution that:

- complies with relevant NSW legislation
- contains a hunting code of conduct or practice, such as the NSW Game Hunting Licence Code of Practice.
- contains disciplinary provisions that allow the AHO to take action against any member found to have breached the Code of Practice or relevant legislation in NSW.

You must be a current member of an AHO to apply for and maintain your NSW R-Licence.



## Who regulates hunting in NSW?

DPI Hunting is part of NSW Department of Primary Industries. It is responsible for administering the *Game and Feral Animal Control Act 2002* and the *Game and Feral Animal Control Regulation 2022*.

Some of DPI Hunting's functions are to:

- administer game hunting licensing services

- implement and conduct game hunting enforcement and compliance operations
- develop and deliver hunting education courses
- administer public land hunting and native game bird management
- undertake research into game and feral animal control.

Other legislation administered by different NSW government agencies may apply to specific types of hunting or the hunting of certain wildlife species.

In Unit 2 of this course : Hunting laws in NSW, we explore other legislation that may impact on different hunting activities.



## Goals of hunter education — Hunter LEAP

The most important aspect of hunter education is to minimise or eliminate the risk of a firearm or hunting-related incident.





Before a hunter takes to the field, they should have competent hunting and firearms handling skills. Through hunter education, DPI aims to ensure that all hunters comply with laws and regulations and act in an ethical, safe and responsible manner.

Hunting laws are regularly reviewed and are subject to change, requiring hunters to keep up to date with new legislation. Attending supplementary education programs helps hunters maintain and even increase their knowledge and skillsets.

Hunter LEAP covers a broad range of topics:

- access to lands
- hunting laws
- animal welfare
- hunting ethics
- respect for nature and the environment
- hunter safety
- hunting and shooting skills.

---

Hunter's tip – Contact your Hunter LEAP provider or trainer for more information on the available Hunter LEAP training courses. A list of Hunter LEAP providers can be accessed on the DPI Hunting website.

---

## International Hunter Education Association

The International Hunter Education Association-USA (IHEA-USA) is the professional hunter education association affiliated with every U.S.-based hunter education program. IHEA partner countries outside of the U.S. form the IHEA World Charter and provide international hunter education standards to South Africa, Europe, Mexico, Canada and Australia.



The mission of IHEA-USA is simple: To continue the heritage of hunting worldwide by developing safe, responsible, knowledgeable and involved hunters.

The primary goals of the IHEA-USA include:

- increase awareness and participation in a responsible and safe hunting tradition
- continue to improve the methods and value of hunter education
- further the skills and ranking of hunter education administrators and instructors
- help better the hunter and hunting images to all non-hunters
- provide international reciprocal hunter education recognition for all IHEA-USA partner countries.

On an annual basis, the IHEA-USA provides peer reviews to all hunter education programs. This review process assists every partner of theirs in evaluating their hunter education standards while enhancing their delivery and assessment methods and providing an educational framework that exceeds the minimum standards required by legislators.

The NSW Hunter Education Program has been endorsed by IHEA-USA and is known as IHEA-AU. Hunter LEAP and the NSW R-Licence Accreditation Course are recognised internationally by each IHEA partner and can be used as evidence for the completion of approved hunter education when purchasing overseas hunting licences in partner countries.

---

Hunter's tip – Please check your eligibility with each IHEA member agency before you purchase an overseas licence.

---

## Where do licence fees go?

All game hunting licence fees in NSW are held in the Game and Pest Management Trust Fund. These funds are used to:

- fund the Game and Pest Management Advisory Board
- detect and combat illegal hunting
- administer research into game and pest animals.

Every game hunting licence issued is an investment in the success of safe, ethical and regulated hunting in NSW.

## Game and Pest Management Advisory Board

The Game and Pest Management Advisory Board is appointed under the *Game and Feral Animal Control Act 2002* and represents the interests of licensed hunters in NSW. The Board provides independent advice to the Minister for Agriculture and DPI on regulated hunting and game and pest animal management in NSW.

The board performs the following legislated objectives:

1. Represent the interests of licensed game hunters in matters arising under the Act.
2. Provide advice on request to the Minister or the Regulatory Authority on game and feral animal control.
3. Provide advice on request to the Minister on priorities for expenditure on research from the Game and Pest Management Trust Fund.
4. Provide advice to the Minister or the Regulatory Authority on educational courses relating to game hunting.

---

Hunter's tip – Licensed hunters may send feedback and suggestions to board members by emailing [gameandpest.advisoryboard@dpi.nsw.gov.au](mailto:gameandpest.advisoryboard@dpi.nsw.gov.au)



## UNIT 2: HUNTING LAWS IN NSW



### Introduction and learning objectives

In this unit, we explore the role of legislation in regulating hunting on private and public lands in NSW, and how it maintains the reputation of safe, responsible and ethical hunters.

The unit objectives are:

- understand why we have hunting laws
- know where to find specific NSW legislation
- know which pieces of legislation apply to hunting in NSW
- understand and comply with the NSW Game Hunting Licence Code of Practice
- search for information relating to companion dogs
- show awareness of hunting Inspectors and the consequences for breaking the law.

---

Hunter's tip – For more information about hunting in NSW, search for [DPI Hunting](#).

---

### Why do we have hunting laws?

Hunting laws are essential in ensuring public safety and to regulate the activities of hunters on both private and public lands. Legal and licensed hunters understand that hunting is a privilege that can be taken away if a hunter does not adhere to the law.

The following reasons support the need for hunting laws in NSW:

1. **Protect the community from harm:** Public safety and protecting the community are the main reasons for hunting laws. Licensing and education standards aim to minimise hunting-related incidents, make hunting a safe and enjoyable activity and meet community expectations. Illegal hunting and trespassing negatively impact rural communities and enforcement agencies. Hunting laws provide the means for legal hunters to distinguish themselves from those determined to do the wrong thing and have a deterrent effect on illegal hunting.
2. **Protect wildlife and the environment:** Animal welfare, ethical hunting techniques and regulating the harvest of some species ensure that animals are hunted ethically and humanely. A hunter's actions and treatment of wildlife and the environment have a direct impact on the way society perceives hunting.

The humane treatment of hunted species is legislated in several Acts, most importantly the *Prevention of Cruelty to Animals Act 1979* and the *Game and Feral Animal Control Act 2002*. All native animals are protected by law, and only specific overabundant species, or those damaging agricultural crops, can be sustainably harvested under special permits or strict regulations.

3. **Regulate hunting on public land:** Public land is there for the whole community to enjoy. Hunting legislation, regulation and conditions ensure the safety of hunters, forestry employees and other public land users. Without these rules, safety may be compromised, and some unregulated activities may result in a serious incident.
4. **Maintain standards:** Hunting laws are in place to benchmark high standards of ethical and safe practices to protect hunters and the community. To protect the integrity of regulated hunting in NSW, it is important to distinguish between licensed, responsible hunters and illegal hunters who do the wrong thing. Mandatory hunter education, such as this course, promotes the right behaviours and attitudes that set apart licensed hunters.



## Where to find legislation

Information on hunting laws in NSW can be found on the NSW Parliamentary Counsel's Office website: [www.legislation.nsw.gov.au](http://www.legislation.nsw.gov.au) (in the search bar, type in the name of the Act you want to find).

## Legislation that applies to hunting

All hunters must be aware of and obey all NSW legislation that relates to hunting, animal welfare and the use of firearms. The following legislation applies to hunting activities in NSW.

### *Game and Feral Animal Control Act 2002*

*The Game and Feral Animal Control Act 2002* and its Regulation 2022 are administered by DPI Hunting. The Act provides a framework for the effective management of introduced species of game animals and for responsible and orderly hunting of game animals on public land. The Regulation sets out specific rules, standards and conditions within that framework.



The Act recognises three levels of regulation that hunters must always abide by. These levels will be discussed throughout this course:

1. Legislation.
2. Standard and special licence conditions that are attached to a game hunting licence.
3. Public land hunting conditions and written permission conditions that are specific to each area.



## Hunting licence conditions

There is a set of legislated conditions attached to every NSW game hunting licence. These conditions set out legal and ethical obligations that you must comply with to legally carry out any hunting activity.

It is your responsibility to know, understand and comply with all conditions that apply to your licence.

### Part 1 – General hunting conditions

1. Definitions in this part
2. You must carry your licence at all times while hunting and produce it on request by a Hunting Inspector, Police Officer or landowner/occupier.
3. Hunters under the age of 18 must hunt under the close personal supervision of an adult hunter (at least 18 years of age) who holds the same type of licence (general or restricted); in the case of restricted categories, both minor and adult must have the same hunting method listed as a category on their licence.

Minor hunters must hold a Minor's firearms permit (issued by the NSW Police Force before using firearms to hunt.

4. You must not hunt game animals fleeing fire or smoke, or light a fire for that purpose.

### Part 2 – Hunting on declared public hunting land

5. You must have written permission to hunt before entering public land for hunting, produce your written permission on request by a

Hunting Inspector, Police Officer or landowner/occupier and comply with all conditions of that permission as well as any reasonable direction given by the landowner/occupier.

When supervising a minor under the age of 18, both the minor and the supervisor must hold a valid written permission.

You must submit a harvest return within 30 days after the expiry of your written permission on any form approved by NSW DPI.

6. You must not lay any type of bait, grain, fruit, meat, mineral block, animal carcass or other types of attractant to assist in the hunting of animals on declared public land.
7. You must not hunt or cause, permit or assist the hunting of animals from a motor vehicle; this does not include using a dog to search for animals if the dog is tied up, caged or restrained, or motorised wheelchairs that may be used by individuals with a disability that prevents them from hunting on foot.
8. When hunting using dogs on public land, each dog must:
  - be identified in the way required by the *Companion Animals Act 1989* (i.e. microchipped), and
  - be wearing:
    - a collar with a metal tag or label with the owner's name, address and phone number
    - a radio tracking collar (that is switched



on and show the position of the dog)  
or be on a lead.

- not be left or abandoned

If the dog is being used to:

Hunt deer:

- dogs must only be used to locate, point or flush deer
- you must not use more than 1 dog when hunting alone
- you must not use more than 2 dogs when hunting as part of a group

Hunt game birds:

- dogs must only be used to locate, flush, point or retrieve.

Hunt pigs:

- dogs must only be used to locate, hold and bail pigs
- you must not use more than 3 dog when hunting alone
- you must not use more than 5 dogs when hunting as part of a group

### Part 3 – Special provisions relating to game birds

(Note: To hunt native game birds on private land, your licence must be endorsed for game bird hunting.)

9. Definitions in this part
10. You must not hunt, or cause, permit or assist the hunting of non-indigenous or native game birds from an aircraft, watercraft or motor vehicle; except if you are a commercial hunter.

11. You must not hunt, or cause, permit or assist the hunting of non-indigenous or native game birds using any bait, lure, decoy or live animal, except game bird decoys or callers (a planted crop is not considered a bait or lure).
12. Native game bird hunters must have permission to hunt native game birds from a landholder who holds a valid native game bird management licence; must only hunt native game birds as per the available property allocation and comply with all reasonable directions given by the landholder.
13. If hunting native game birds at night, from 30 minutes after sunset to 30 minutes before sunrise, you must use use a light of sufficient brightness to clearly see and identify the species being hunted, and the native game birds must be in the immediate vicinity of, or likely to adversely impact, a planted crop.
14. A hunter must not use a dog, or permit a dog to be used, to hunt game birds unless the dog is only used to locate, flush, point or retrieve the birds.



## NSW Game Hunting Licence Code of Practice



In NSW, all licensed hunters must comply with the Code of Practice when carrying out any type of hunting activity. The code is a mandatory condition of all NSW game hunting licences to promote safe and ethical hunting practices.

Penalties apply for breaches of the code.

1. **Safe handling of firearms:** Where firearms are used, hunters must follow all safe use and handling practices. Game hunting licence holders must comply with the *Firearms Act 1996*.
2. **Permission required to hunt on land:** A game hunting licence does not automatically authorise the holder of the licence to hunt on any land. Subject to the Game and Feral Animal Control Regulation 2022, the holder of a NSW game hunting licence must not hunt any land without the express authority of the occupier of the land.
3. **Target identification and safety:** The holder of a game hunting licence must not discharge a firearm or bow at a game animal if:
  - it cannot be clearly seen and identified, or

- there is a discernible risk of injury to any person, or
- there is a discernible risk of significant damage to any property.

4. **Obligation to avoid suffering:** The holder of a game hunting licence must:

- not inflict any unnecessary pain or suffering on a game animal being hunted, and
- use a firearm and ammunition or bow and arrow that is likely to achieve a humane kill of the game animal being hunted, and
- only shoot within the reasonably accepted killing range of the firearm and ammunition or bow and arrow being used, and
- target the game animal being hunted so that a humane kill is likely

5. **Lactating females with dependent young:**

If a holder of game hunting licence kills a lactating female game animal, the holder of the game hunting licence must make every reasonable effort to locate and humanely kill any dependent young.

6. **Wounded animals:** If a game animal is wounded by the holder of a game hunting licence, the holder of the game hunting licence must make every reasonable effort to locate any wounded game animals and kill them quickly and humanely.

7. **Use of dogs:** Subject to the Game and Feral Animal Control Regulation 2022, dogs and

other animals may be used while hunting only if:

- their use is not in contravention to the *Prevention of Cruelty to Animals Act 1979*
- their use is with the permission of the occupier of the land concerned.

- *Summary Offences Act 1988*
- *Biosecurity Act 2015*
- *Companion Animals Act 1998*

We will look at the most relevant Acts that regulate hunting activities.

### Other legislation that applies to hunting



There are other pieces of legislation that you must comply with to meet the ethical standard set out in the NSW Game Hunting Licence Code of Practice. Breaches of the code may be subject to penalties under the *Game and Feral Animal Control Act 2002* as well as other pieces of legislation, such as the *Inclosed Lands Act 1901* for trespass offences.

In addition to the *Game and Feral Animal Control Act 2002*, hunters need to be aware of these other important Acts.

- *Forestry Act 2012*
- *Firearms Act 1996*
- *Prevention of Cruelty to Animals Act 1979*
- *Inclosed Lands Protection Act 1901*

### **Forestry Act 2012**

*The Forestry Act 2012* provides for the dedication, management and use of State forests and other Crown-timber land for forestry and other purposes.

Hunters should be aware this Act covers:

- hunting and the possession of hunting equipment –firearms and other hunting related equipment in a State forest is only permitted with a valid R-Licence and written permission.
- unauthorised structures –buildings and structures including tree stands are prohibited in State forests.
- registered vehicles -all vehicles in State forests must be registered and display an unobscured number plate.



## ***The Firearms Act 1996***

Hunters seeking to use and possess a firearm in NSW must hold a firearms Licence issued by the NSW Police Force Firearms Registry, that administers the *Firearms Act of 1996*. Interstate residents must hold an equivalent licence issued by their state authority before entering NSW with a firearm.

For recreational hunting, your firearms licence must be endorsed for the appropriate category of firearm and the relevant genuine reason.

Under this Act, firearms are designated into categories based upon their action type. Firearms used for recreational hunting and vermin control generally fall into the categories of A and B.



**Category A:** Air rifles, Rimfire rifle (other than self-loading), Shotgun/rimfire combinations, Shotgun (other than pump-action or self-loading)

**Category B:** Muzzle-loading firearms (other than pistols), Centrefire rifles (other than self-loading), Shotgun/centrefire combinations

**Category C:** Prohibited except for limited purposes. Self-loading rimfire rifles with a magazine capacity of no more than 10 rounds,

Self-loading shotguns with a magazine capacity of no more than 5 rounds, Pump-action shotguns with a magazine capacity of no more than 5 rounds

**Category D:** Prohibited except for official purposes. Self-loading centrefire rifles, Self-loading rimfire rifles with a magazine capacity of more than 10 rounds, Self-loading shotguns with a magazine capacity of more than 5 rounds, Pump-action shotguns with a magazine capacity of more than 5 rounds, any firearm to which a category C licence applies

**Category H:** Handguns (including blank firing handguns)

**Firearms dealer:** Licence specifies which firearms may be possessed by the individual dealer

**Firearms collector:** Licence specifies which types of firearms may be possessed by the individual collector

Your Firearms Licence is also restricted by the genuine reason listed on the licence.

To hunt with an appropriate category of firearm in NSW, you must have the genuine reason of Recreational hunting and vermin control.

You can also have more than one genuine reason attached to your firearms licence.

Each category of firearm must be stored and transported in accordance with the legislation.

We will cover more information relating to the use



of firearms in R-Licence Category 1 – Hunting with firearms (rifles, shotguns and blackpowder firearms), in Section 2 of this course.

Commercial and professional hunters may use other categories of firearms if they are appropriately licensed and hold the relevant permits. For more information, contact the NSW Police Force Firearms Registry.

### ***Prevention of Cruelty to Animals Act 1979***

The *Prevention of Cruelty to Animals Act 1979* (PoCTA) aims to prevent an animal's unnecessary pain or suffering.

Hunters should be aware this Act requires that:

- no unnecessary pain or cruelty is caused to an animal being hunted or killed
- hunting dogs must receive veterinary treatment if injured
- dogs must be restrained or caged while on the back of a moving vehicle
- transportation of animals must not unnecessarily inflict pain
- dogs or other animals that are kept and used



for hunting must receive food, drink, housing and regular exercise

- possession or use of a 'shock' collar is prohibited.

### ***Inclosed Lands Protection Act 1901***



For the activity of hunting, inclosed lands is any land that has a fence, boundary or border.

Hunters should be aware this Act covers:

- trespass
- aggravated trespass
- tagged domestic goats.

### ***Summary Offences Act 1988***

Hunters should be aware this Act covers:

- hunting without permission – similar to aggravated trespass under the *Inclosed Lands Protection Act 1901*, it's illegal to enter private land and hunt for any animal without permission





- knives in public places — unless there is a reasonable excuse, such as lawful hunting, knives must not be possessed in public places and must be securely stowed when hunting finishes.

### ***Biosecurity Act 2015***

Biosecurity is a shared responsibility to protect our economy, environment and community from pests, diseases, weeds and other contaminants.

The *Biosecurity Act 2015* places a ‘general biosecurity duty’ on every person in NSW, which means that anyone who deals with biosecurity matter must prevent, eliminate, or minimise any risk they encounter.

Hunters have an obligation under this Act to stop the impacts of pests, diseases, weeds and other contaminants on the environment and agricultural properties. This includes not possessing or transporting live:

- feral pigs
- deer
- foxes
- feral cats
- feral camels
- rabbits.

---

Important - There are heavy penalties for anyone found transporting, possessing or releasing game and feral animals for the purposes of hunting them or their descendants.

---

Many properties in NSW have a biosecurity management plan, and a sign will be displayed at the entrance. As well as having permission to enter the property, other responsibilities for hunters include:

- measures to prevent the spread of weeds, such as by washing vehicles on entry
- reporting pest animal activity
- reporting any sick animals or signs of disease.



Before you enter that land, you must comply with all the measures outlined on the sign or you could face serious penalties, including on the spot fines.

### ***Companion Animals Act 1998***

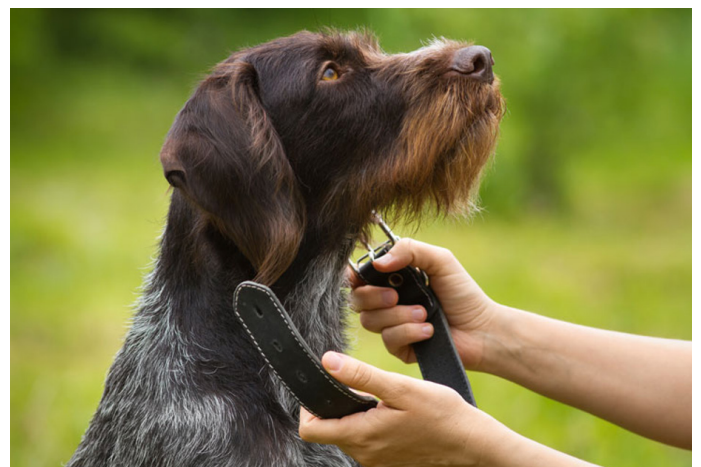

NSW State forests and public land are there for all to enjoy. There are a variety of outdoor and recreational activities that people participate in within our state forests, and taking a dog along with you adds to the enjoyment.

Hunters do not need to list any non-hunting dogs on their written permission but must always

comply with the *Companion Animal Act 1998*, which sets out responsibilities while your dog is in a public place.

When a licensed hunter, who holds a valid written permission, wants to take a non-hunting companion dog with them, they must adhere to the following conditions. The dog must:

- be registered and microchipped.
- be wearing a collar with a metal tag or label that is securely attached and that has your address or phone number.

To hunt any animal on public land using dogs, you must successfully complete R-Licence Category 3- Hunting With Dogs, in Section 2 of this course.

### The role of hunting Inspectors

DPI Hunting Inspectors are authorised Inspectors under the *Game and Feral Animal Control Act 2002*. They are field-based officers and regularly patrol public land that is declared for hunting. They also take part in joint operations with other regulatory authorities on other lands, including privately owned lands. Hunting Inspectors are a great source of knowledge and want hunters to have a safe and enjoyable hunting experience.

In addition to enforcing NSW hunting laws, they also focus on educating and encouraging hunters to comply with the relevant legislation previously mentioned in this unit.

Under the Act, hunting Inspectors can also be:

- NSW Police Officers
- National Parks and Wildlife Service officers
- NSW Forestry Corporation employees

- other NSW Government employees.

The DPI Hunting website provides information to help hunters understand their obligations and responsibilities so they can act safely and within the law while hunting.

If a hunter breaks any laws, legislation or conditions of their game hunting licence or written permission, they may face significant penalties.

The following penalties may apply to anyone in breach of the law:

- further education
- cautions
- penalty infringement notices
- cancellation or suspension of your hunting licence
- seizure and possible confiscation of hunting related equipment including firearms and vehicles
- court attendance — if convicted, you may face significant fines, court orders and even imprisonment.

Remember to always comply with the laws when you are hunting. Breaking the law not only affects you but also affects the reputation of hunting and other hunters.



## UNIT 3: BEING AN ETHICAL AND INVOLVED HUNTER

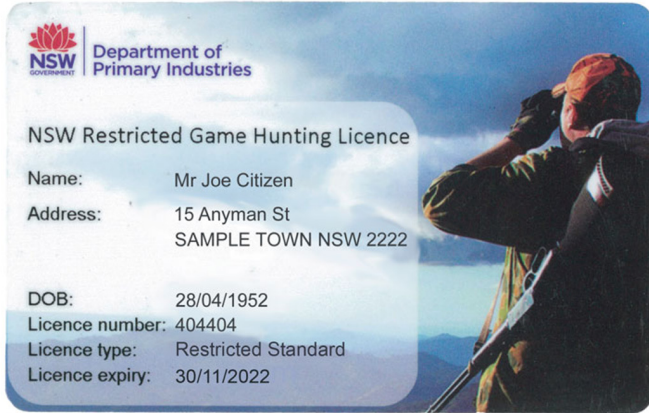

### Introduction and learning objectives

Today's hunter needs to develop personal hunting rules and ethics to maintain community support for this legitimate activity. Ethics set personal boundaries as to how hunters are prepared to hunt within the framework of existing laws.

The unit objectives are:

- understand the moral and ethical responsibilities of hunting
- comply with the four R's of hunting
- understand why we hunt
- describe the role of an ethical hunter.

### Being an ethical and involved hunter

Hunting ethics develop and grow from your experiences, an understanding of the principles of wildlife management and respect for the animals you hunt.

The NSW public land hunting program requires a high level of ethical behaviour and responsibility



from hunters to ensure the continuation of legal hunting in this state. These core hunting values should be communicated through licence holders to their hunting fraternity and the wider community.

All hunters have an obligation to do the right thing in the way they hunt an animal, to respect landholders' property and to interact safely with the local community. Each hunter's behaviour ultimately shapes societies attitudes and perceptions about hunting in NSW.

### Hunting is a privilege

Privileges are a right or advantage granted to a specific group of people that are controlled by a set of laws and regulations.



For example, every Australian has the opportunity to drive a car, however, they must have a driver's licence, which can be cancelled or suspended if they break road laws. Australians without a driver's licence do not have the privilege of driving.



Hunting, therefore, is an example of a privilege. With the appropriate licences, a hunter may handle and possess firearms, and hunt on public land in NSW. Violating any laws related to hunting can result in these privileges being revoked.

## Why we hunt

Hunting is an age-old tradition that evolved from the need to acquire food. When you ask a hunter why they hunt, it is likely that you will never hear the same answer twice. All hunters have their own sets of values and reasons for taking part in hunting.

The motivation to hunt may include:

**Nature:** Hunting can give people the opportunity to find a release from the stresses of day-to-day life and spend some time in nature. A few days in the bush allows you to slow down, clear your mind and reconnect with nature.

**Tradition:** For many, hunting is simply a way of life and a family tradition passed down through generations. These hunters usually start at a young age and remain hunters for life.



**Friendship and family bonds:** Some hunters enjoy spending time outdoors with their friends or colleagues to develop or strengthen friendships.

Family bonds are strengthened when children are mentored in the art of hunting.

**Food:** Many people prefer wild game to store-bought meat. Wild game is known to have a lower fat content and supports the current trend of obtaining free-range meat. Many also prefer the taste of wild game to domestic, farmed animals.

**Pest control:** Many hunters have long-standing relationships with landholders. Helping reduce the impact of problem animals helps the farmer and the environment while also reducing impacts on the community. Hunting is seen as an effective tool in managing wildlife populations around the world.

You may have noticed that many of these reasons have little to do with shooting a firearm or harvesting an animal. For many hunters, hunting is about the entire experience, from setting up camp and lighting a fire through to enjoying the outdoors.

## The ethical hunter

Every hunter develops their own ethical standards, which are a personal code of practice that determines how they approach their hunting activities. Within current legal boundaries there may exist some hunting practices that other hunters consider unethical when measured against their own personal code of practice.

A hunter's personal hunting ethic goes well beyond social expectations and extends to reasons for the 'why' and 'how' of hunting.



Many hunters are very specific in their hunting style and may practice only one form of hunting, such as rifle hunting or bowhunting. They may have expert knowledge in one method and be completely novice

in another. The context of a hunt will determine how a hunter applies their hunting ethic.

For example:

- Is the hunt for pest control or for meat?
- Are the hunted animals abundant or sparse?
- Is the hunt on private or declared public land?
- Is the hunt a commercially guided hunt or a weekend outing with friends?

When hunting on both private and public lands in NSW, the minimum ethical standard expected of all hunters is based on a very sound and proven value – **Respect**.

As a part of holding the NSW game hunting licence, hunters are required to follow the ‘4 R’s’ of hunting: respect for law, respect for landowner and land manager, respect for environment and respect for animals.

### 1. Respect for the law



Ethical hunters show respect for the law by:

- being role models who obey and promote compliance to all laws, including game hunting, access to lands and firearm laws
- ensuring they have permission before entering any land
- obeying all legal requirements of the landholder
- obeying total fire bans and ensuring they adhere to fire danger ratings
- reporting to DPI Hunting, landholder, manager or police all unusual or suspicious behaviour or illegal activities.

### 2. Respect for the landowner and land manager



Ethical hunters show respect for the landowner and land manager by:



- understanding that when entering property with permission, they are a guest of the landowner and must treat the property with respect
- obeying all reasonable requests and directions of the landowner
- ensuring they gain a clear understanding of property boundaries and the areas they have permission to access
- looking for opportunities to assist landowners in return for the hunting privileges they have been afforded
- treating all other people's opinions and property with respect
- learning about the likelihood or presence of any traditional owner's sites or places and not, under any circumstances, disturbing them.

### 3. Respect for the environment



Ethical hunters show respect for the environment by:

- disposing of all litter and garbage and empty

shell cases properly

- driving on formed tracks and trails and not where their vehicle will cause environmental damage
- working to preserve the environment and supporting biodiversity conservation principles
- taking the necessary precautions and safety measures when lighting campfires
- understanding the basic principles of bushcraft and survival and applying them in the field.

### 4. Respect for the animals

Ethical hunters show respect for the animals by:

- learning to shoot accurately, safely and always with the intention of ensuring a humane kill
- learning everything they can about the game they hunt, including their habitat, habits and life cycles
- ensuring they are skilled in the hunting methods they use
- transporting their harvest in a respectful manner
- learning to fully utilise the animals they harvest.



## Native animals

Native animals are protected in NSW and cannot be hunted on public land.

Some native species can be hunted on private land when the landholder and hunter are appropriately licensed. More information can be found in Unit 6- Hunting on private land.

It is important that hunters only target species that are permitted to be hunted under the *Game and Feral Animal Control Act 2002*.



## How can hunters change the perception of hunting?

Responsible hunters must also be involved hunters. They must do their part to ensure that hunting remains a legitimate activity for their enjoyment and the enjoyment of others.

When members of the public see hunters behaving in an unethical or offensive manner, this reflects badly on everyone who engages in this sport. Ethical and safe hunters understand that their behaviour sets us apart from non-ethical hunters and illegal hunters.

---

Hunter's tip – The public is more concerned with hunter behaviour rather than the activity of hunting.

---



## Social media

Using social media to display your successful hunts should always be approached with caution. Never post images of animals with massive wounds, large amounts of blood or distasteful hunting scenes. These images reflect poorly on all hunters and remain on a public forum that can be accessed by anyone at any time. You should only post images or stories that promote safe and ethical hunting. Always be mindful of the negative and legal implications of social media.

Changing society's perception of hunters can ensure that as a safe hunter, you can continue to provide a range of benefits to the NSW community.

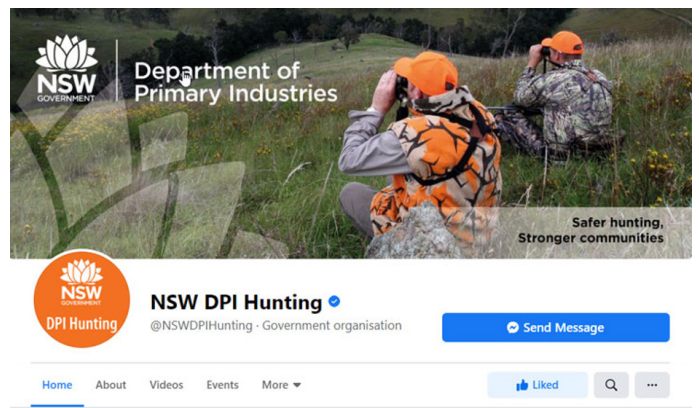

## UNIT 4: ANIMAL IDENTIFICATION, WILDLIFE MANAGEMENT AND THE WELFARE OF HUNTED ANIMALS



### Introduction and learning objectives

Animal identification is a fundamental aspect of ethical hunting as are your responsibilities under animal welfare legislation. In this unit, we will explore the different rules that relate to the types of animals that can be hunted in NSW.

The unit objectives are:

- know how to identify species that can be hunted in NSW
- know how to harvest animals humanely
- know where to aim at an animal to ensure a humane kill
- handle successful and unsuccessful shots
- understand your obligations under the *Prevention of Cruelty to Animals Act 1979*.

There are different rules for the different species that may be hunted on public and private lands in NSW. Remember that you must hold a NSW R-Licence to be able to hunt on public land.

### Identifying game animals



Before you can determine whether a potential shot is legal and ethical, you must first be able to properly identify the animal beyond all doubt.

Wildlife identification is a necessary skill

for responsible hunters. Before heading out for a hunt, you should not only study the animals you are hunting but also other animals you might encounter and whether they are protected.

The *Game and Feral Animal Control Act 2002* sets out species that may be hunted on public or private lands in NSW. Schedule 3 of the Act classifies these species as game animals and provides for three categories. The category of a game animal determines whether they may be hunted on public or private land by holders of a game hunting licence.

The three categories are:

- **Part 1:** non-indigenous game animals
- **Part 1A:** native game birds (private land only)
- **Part 2:** non-indigenous animals.



## Part 1: Non-indigenous game animals

These animals can be hunted if you hold a game hunting licence.

- Bobwhite Quail
- California Quail
- Guinea Fowl
- Partridge
- Peafowl
- Pheasant
- Spotted Dove
- Turkey

---

Hunter's tip – These animals can be hunted on private land when you hold a game hunting licence.

They can also be hunted on public land when you hold an R-Licence and the species are listed as 'can be hunted' on the Written permission.

---



*Bobwhite Quail*



*California Quail*



*Guinea Fowl*



*Partridge*



*Peafowl*



*Pheasant*



*Spotted Dove*



*Turkey*



## Part 1A: Native game birds (private land only)

There are special restrictions for hunting native game birds in NSW. They can only be hunted on private land under the Native Game Bird Management Program and only where the landowner or occupier is able to show that native game birds are damaging their agricultural crops.

To participate in the Native Game Bird Management Program and hunt these species, you must hold a game hunting licence and have successfully completed the Waterfowl Identification Test (WIT). After completing these requirements, you must seek endorsement for the program from DPI Hunting.

In addition to being part of the native game bird program, there must also be a NSW DPI approved state-wide hunting quota for the following species, as well as an active species allocation for each property where native game birds will be hunted.

- Australian Shelduck or Mountain Duck
- Australian Wood Duck or Maned Duck
- Black Duck or Pacific Black Duck
- Blue-winged Shoveler or Australasian Shoveler
- Chestnut Teal
- Grass Whistling Duck or Plumed Whistling Duck
- Grey Teal
- Hardhead Duck or White-eyed Duck
- Pink-eared Duck
- Wandering Whistling Duck, Water Whistling Duck or Whistling or Wandering Tree Duck



*Mountain Duck*



*Australian Wood Duck*



*Black Duck*

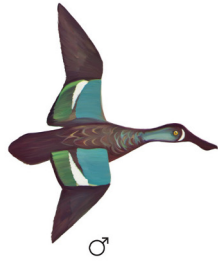

*Australasian Shoveler (male)*



*Australasian Shoveler (female)*



*Grass Whistling Duck*



*Water Whistling Duck*



*Chestnut Teal (male)*

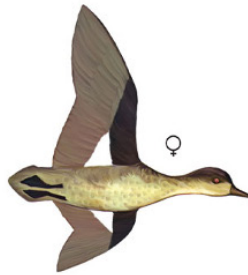

*Chestnut Teal (female)*



*Grey Teal*



*Pink-eared Duck*

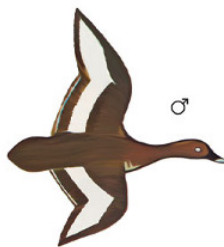

*Hardhead Duck (male)*

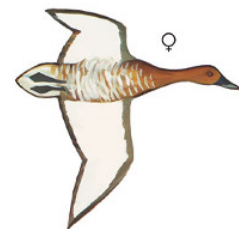

*Hardhead Duck (female)*

## Quail and pigeons

The following native game bird species of quail and pigeon may not be hunted in the absence of a state-wide quota. Currently, there is not enough scientific information on populations of these species to provide for a hunting quota.

More information on the Native Game Bird Management Program can be found in Unit 6: Hunting on private land.

### Quails

- Brown Quail
- Stubble Quail

### Pigeons

- Common Bronzewing Pigeon
- Crested Pigeon

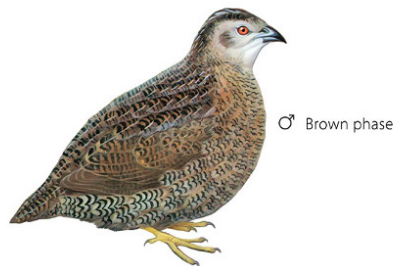

*Brown Quail*



*Stubble Quail*



*Common Bronzewing Pigeon*



*Crested Pigeon*

## Part 2: Non-indigenous animals

To hunt the animals in the final category of game animals on public land, you must hold an R-Licence and a written permission. However, you do not need a licence to hunt them on private land, as you do with the first two categories.

If a particular species is not listed in the schedule of game animals, it must not be hunted on public land. Even if a species is listed in the Act, it may only be hunted on public land if listed on a written permission.

- Deer
- Rabbit
- Pig
- Hare
- Fox
- Dog (other than dingo)
- Goat
- Cat
- Feral Pigeon
- Common or Indian Myna
- Common Starling



*Rabbit*



*Hare*



*Fox*



*Goat*

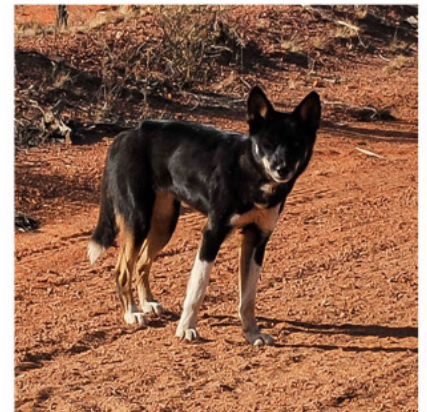

*Dog*



## Deer species

There are seven species of deer that can be found on NSW public land. You can hunt these species on public land if you hold an R-Licence.

Important – there is no licence requirement to hunt these species on private land.

- |    |             |    |              |
|----|-------------|----|--------------|
| 1. | Fallow Deer | 5. | Hog Deer     |
| 2. | Red Deer    | 6. | Chital Deer  |
| 3. | Rusa Deer   | 7. | Wapiti (Elk) |
| 4. | Sambar Deer |    |              |

---

There is no licence requirement to hunt these species on private land. You can also hunt these species on public land but only if you hold an R-Licence.

---



*Fallow Deer*



*Red Deer*



*Rusa Deer*



*Sambar Deer*



*Hog Deer*

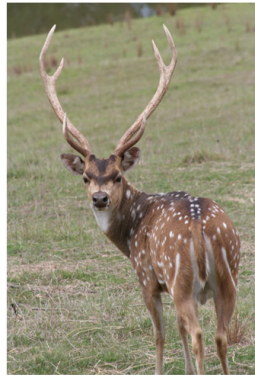

*Chital Deer*



*Wapiti (Elk)*

## Identifying good habitat



Wildlife species make their homes in any suitable location that satisfies their basic needs. There are five basic needs that determine good habitat. When all five are met, hunters will be likely to find a variety of wildlife populations.

Public lands in NSW, specifically State forests, are working forests that generally offer good habitat.

1. **Food:** All animals need to eat. If grasses, nuts, berries, seeds, bugs and browse plants are available, animals will frequently inhabit these areas.
2. **Water:** All animals need water to survive. The water could come from a dam, lake, river or creek. Almost every State forest in NSW has a permanent water source to assist with timber production and to help battle bushfires.
3. **Shelter:** Just like people, all animals need shelter. The shelter protects them from extreme weather, helps them hide from predators and care for their young.
4. **Space:** All animals need space to roam. However, dominant animals or territorial

species may require more space than others.

5. **Arrangement:** Animals need food, water, cover and space arranged in such a way that it is beneficial for them to stay in that area. If all of the habitat needs are met, you should see wildlife.

## Animal welfare

People utilise animals in a variety of ways. We keep animals as pets and companions and train them to display specific behaviours, such as those that assist a hunter.

At times, we harvest both domestic and wild animals for food and other animal products.

The question with hunting is not ‘if we should hunt’, but rather, what are the welfare principles we need to apply to the way we hunt?

Animals must always be hunted ethically and humanely, without inflicting unreasonable or unnecessary pain and suffering on them.

Animals, especially dogs, used for hunting also have welfare concerns their owners must be aware of. These concerns are discussed in more depth in R-Licence Category 3-Hunting with dogs, in Section 2 of this course.

The *Prevention of Cruelty to Animals Act 1979* specifically deals with the way all animals must be treated. It is every hunter’s duty to know and abide by the conditions of this Act.



## Mandatory welfare requirements

In Unit 2 - Hunting laws in NSW, we learnt about the NSW Game Hunting Licence Code of Practice. As hunters, the four cardinal animal welfare principles enshrined in the code are:

1. No animal may be inflicted with unnecessary pain.
2. All reasonable steps must be taken to locate and quickly kill a wounded animal.
3. If a female with suckling or dependent young is taken, every reasonable effort is required to find and kill the young.
4. Dogs and other animals may be used to assist hunters provided that this use is in accordance with the *Prevention of Cruelty to Animals Act 1979*.



## 5. Humane harvesting of hunted animals

Targeting the appropriate vital zone is crucial to achieving a quick, clean harvest of game animals. As the aim of ethical hunting is not to wound an animal, only to have it run away and not be found,

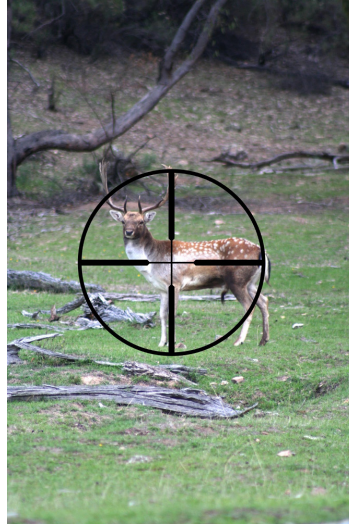

it is every hunter's responsibility to ensure they can harvest the animal quickly, without any unnecessary pain or suffering.

Death can occur almost instantaneously when the projectile hits a

certain part of the body. These areas are referred to as the 'vital zones'. They are made up of internal organs, nerves and blood vessels. Any disruption to these zones will cause rapid death.

## Vital zones

There are only two acceptable points of aim when hunting animals with firearms:

1. **Chest-kill zone.**
2. **Head-kill zone.**

If you are bowhunting or hunting pigs with dogs, you must only target the chest-kill zone.

**Chest-kill zone** – The chest is the largest vital area found on all game animals. The chest is the recommended and most commonly targeted vital zone, as the likelihood of wounding or losing the animal is minimised.

The chest zone is made up of the heart, lungs and major blood vessels. Damage to any of these organs will result in rapid blood loss, leading to unconsciousness and death.

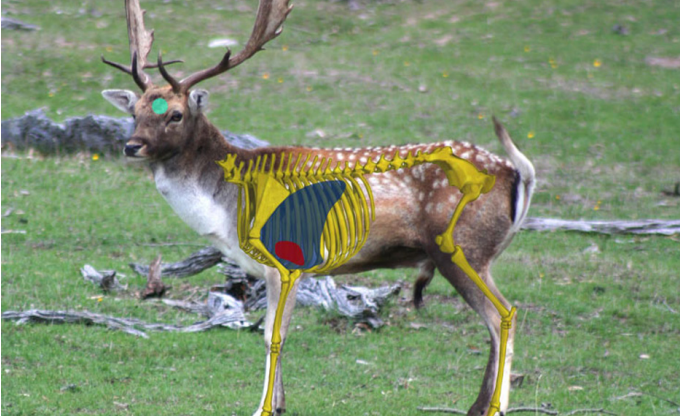

**Head-kill zone** – Bullet placement to the brain will result in instantaneous loss of consciousness and death. The projectile will disrupt the nervous system causing the animal's body to abruptly shut down.

The brain offers a very small target, and a slight miss can severely maim the animal. Wounded animals may take several days to die from a missed head shot, causing unnecessary suffering if they cannot be quickly located and dispatched.

Because the brain is located towards the back of the skull and slightly above the eyes, this shot on a trophy animal may destroy the antlers or horns.

Head shots are not recommended for hunting and should be reserved for highly skilled marksman, using the appropriate rifle and ammunition combination, when carrying out pest control or meat harvesting programs.

Never attempt a head shot when using archery equipment.

## Ethical shot placement using firearms and bows

Proper shot placement refers to the bullet or arrow

hitting the vital zones and resulting in a quick, clean and humane kill. You should not take a shot unless you are certain you can hit the vital areas. If you are unsure, do not take the shot.

A responsible hunter must know when it is appropriate to take a shot and how to hit the vital zones for a quick, clean harvest. These are different shot angles a hunter might encounter in the field.

1. **Broadside:** In the broadside shot, the bullet or arrow can easily pass through the rib cage to hit the heart and lung area, and the hunter has a wider target at which to aim. A properly placed shot will lead to a quick and clean harvest, without wasting much meat. This is often considered the best shot for firearm and bow hunters alike.

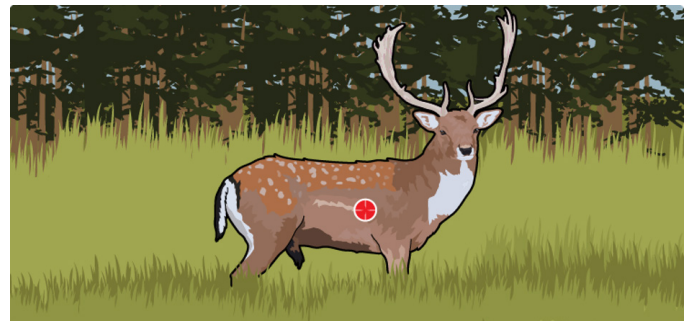

2. **Quartering-away:** The quartering-away shot offers a clear path to the heart and lungs; and if it is on the right side, it will travel through the liver as well. This will result in a very quick harvest of the animal. Though the aiming point at this angle is less than a broadside shot, this is still an acceptable shot for a firearm or bow hunter.





3. **Quartering-toward:** The quartering-toward shot offers an ethical dilemma. The vital organs are protected by the shoulder blade and there is an increased risk of your bullet or arrow missing the kill zone. Firearm hunters are advised to wait for a better shot. Bowhunters should not attempt this shot.

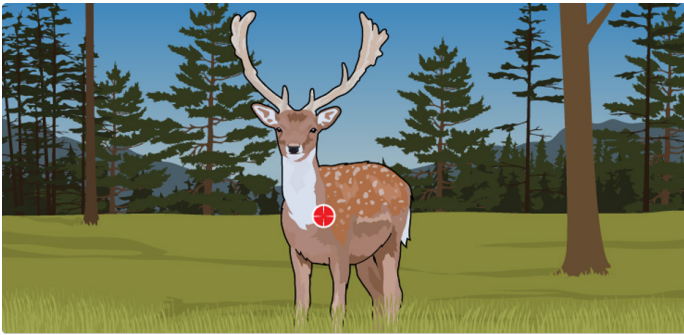

4. **Front shot:** It is very difficult to hit the vital areas in a front shot, since the hunter has a very small area at which to aim, and the bullet or arrow has to travel through bones to reach the vital organs. Again, it is advisable for firearm hunters to wait for a better shot. Bowhunters should always pass on this shot.



chance of hitting any vital area of the animal. This shot is extremely unethical for both firearm and bowhunters. **Never fire at an animal that is heading away from you.**



### Successful and unsuccessful shots

Hunters must always aim for a quick and clean one-shot kill. If you have any doubt your shot will not result in a clean kill, you must not take it.

To make a successful shot:

- stalk as close to the animal as possible without alerting it to your presence
- use the recommended minimum calibre
- make sure your rifle is sighted-in correctly at a range before hunting
- know the trajectory of your rifle and ammunition combination
- do not attempt shots at distances you have not attempted or are not confident in taking
- take a firm, secure rest before you fire
- use the correct breathing and trigger control
- do not flinch
- aim for the vital zones (generally the chest zone)
- never shoot through brush, branches or fences.

## Handle unsuccessful shots ethically

In most cases, following the successful shot rules will result in mortal wounding of the animal, which will die quickly. But not all shots will result in a clean kill. Unfortunately, things sometimes go wrong that are beyond your control.

Perhaps you took the shot, but the animal was hit too far behind the ribs and it fled into thick bush. You know for sure that you made a hit, but the animal is nowhere to be seen. Unfortunately, this can be a harsh reality of hunting.

In the event you lose sight of the animal, do not chase the animal. Keep calm and make sure your rifle or bow is safe.

When following up a lost animal:

- note the direction in which the animal ran
- wait 30 minutes to allow the animal to either expire or bed down
- using bright coloured tape, mark the spot where you took the shot
- slowly approach the spot where the animal was shot and mark it



- look for footprints, blood splatter and tissue
- check the type of blood sign, as this will indicate if a major organ was hit
- slowly begin to follow the blood trail, marking it at five metre intervals
- if you lose the blood trail, go back to your last marker and begin searching again
- once you locate the animal, approach it very slowly and quietly
- if the animal has not expired, apply a safe finishing shot
- remember to remove your marking tape.





## UNIT 5: HUNTING ON PUBLIC LAND



### Introduction and learning objectives

Public land hunting is accessible to anyone who holds an R-Licence and a valid written permission. Before entering public land, such as State forests, for the purposes of hunting, it is important to remember that they are working forests that involve commercial activities as well as other recreational users. Therefore, strict safety measures have been put in place after assessing the risks associated of hunting.

The unit objectives are:

- understand the rules and your responsibilities when hunting on public land
- describe the role of an authorised hunting Inspector
- use navigation skills when hunting on public land
- understand the correct etiquette while hunting on public land
- understand the need for hunting exclusion zones
- be able to identify forest signage.

Hunting is a safe activity. Hunting on public land in NSW has an exemplary safety record with no serious injuries since the program began in 2006. By following the guidelines in this unit, hunters can continue to have a safe and enjoyable public land hunting experience.

### Introduction to written permissions

Before entering any public land area with hunting equipment, hunters must have a written permission which authorises them to hunt. The NSW DPI online booking system generates written permissions on behalf of the Forestry Corporation of NSW (FCNSW). Other public land areas may be managed by different agencies.

Written permissions are specific to each forest and are only valid for the selected dates. Hunters can apply for two written permissions at a time, each for up to seven days. These permissions allow you to be in the forest with your hunting equipment one day before and one day after your hunt.

Written permissions generated online can be stored digitally on a mobile device or printed on paper. R-Licence hunters must carry their digital or printed permission at all times when hunting in the selected forest and must be able to produce the permission when asked by a hunting Inspector.

Each written permission contains information regarding:

- conditions specific to that area
- dates you have booked to hunt

- allowable hunting methods
- your vehicle details which must be accurate
- details of any dogs you will use
- species allowed to be hunted
- areas excluded to hunting
- details of 1080 poison baiting programs, areas of high recreational use or notice of planned public events
- safety and advisory information specific to the selected forest.

Hunters must read, understand and comply with their written permission and should also be fully aware of all general conditions for public land hunting, which are explained further in this topic.

You can check the general conditions at any time on the DPI hunting website.

---

Hunter's tip – Remember to keep your hunting equipment securely stored the day before and the day after your hunt and at all times when your hunting equipment is not being used.

---

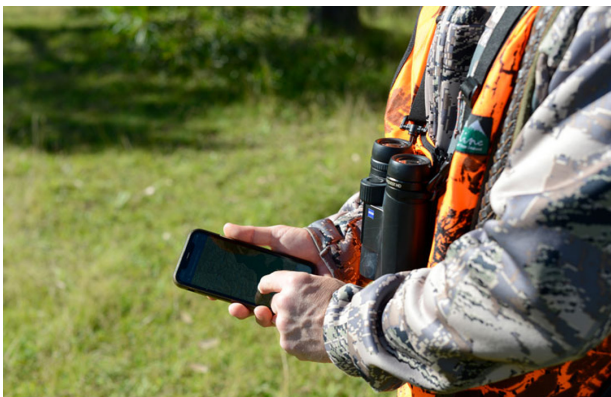

### General conditions

General conditions form a part of your written permission and are the same for all public lands. Breaching any is an offence and a range of penalties apply. Some conditions mean that you need to check for forest closures, fire bans or burning.

Public land includes NSW State forests (including some Flora reserves) that:

- have been declared for hunting under the *Game and Feral Animal Control Act 2002*, and
- are open and available to hunting.

#### 1. **Interference with operations**

You must not interfere with any operations when you are hunting.

#### 2. **Signs, notices and barriers**

You must obey the directions of any sign, notice or barrier encountered when hunting.

Signs must not be removed or defaced in any way.

#### 3. **Rights of other users**

You must not obstruct or impede the right of any other public land user while hunting.

#### 4. **Written permission details**

You must not provide false information when applying for a written permission.

You may only hunt in accordance with the information you provided during your written permission application, including details of vehicles and dogs.

If the details listed on your written permission change before your hunt, you must amend your written permission with the new information and download an updated version.

#### 5. **Intention to hunt**

You must not book a written permission unless you intend to hunt on the dates you have selected for the permission.

If you are unable to hunt on those dates, you must amend or cancel your written permission.



## 6. Closures

You must not hunt on public land during a closure. It's your responsibility to know whether there is a forest closure in force before you hunt. This information is available on the [FCNSW](http://www.forestrycorporation.com.au/visit/closures) and [NPWS](http://www.nationalparks.nsw.gov.au/alerts/alerts-list) websites (www.forestrycorporation.com.au/visit/closures; www.nationalparks.nsw.gov.au/alerts/alerts-list).

## 7. Fires

**Total fire bans:** You must not hunt on public land if a total fire ban is in force. It's your responsibility to know whether there is a Total Fire Ban in that region before you hunt. This information is available on the [Rural Fire Service website](http://www.rfs.nsw.gov.au/fire-information/fdr-and-tobans) (www.rfs.nsw.gov.au/fire-information/fdr-and-tobans).

**Solid fuel fire bans:** You must not use a solid fuel fire if a solid fuel fire ban is in force for that public land. It's your responsibility to know whether there is a ban in place. This information is available on the [FCNSW](http://www.forestrycorporation.com.au/visit/solid-fuel-fire-bans) and [NPWS](http://www.nationalparks.nsw.gov.au/alerts/alerts-list) websites (www.forestrycorporation.com.au/visit/solid-fuel-fire-bans; www.nationalparks.nsw.gov.au/alerts/alerts-list)

**Hazard reduction burns:** You must not hunt in an area of public land if a hazard reduction burn is taking place. It's your responsibility to know whether there is a hazard reduction burn in the area you intend to hunt. This information is available on the [Rural Fire Service website](http://www.rfs.nsw.gov.au/fire-information/hazard-reductions) (www.rfs.nsw.gov.au/fire-information/hazard-reductions).

## 8. Possession of firearms and hunting equipment on public land

You are allowed to be in possession of hunting equipment in the public land area that your written permission is issued for, from one whole day before to one whole day after the valid period of your permission. Your hunting equipment must be stored and not readily accessible outside of your permitted dates.

Your written permission allows you to hunt using specific methods. Your hunting equipment must match the categories approved on your R-Licence as well as the hunting methods approved on your written permission.

To possess and use a firearm on public land, you must hold a current firearms licence issued by your state agency that is endorsed for the category of firearm you are using. Your R-Licence must be endorsed for the 'firearms' category.

You must not possess any type of hunting equipment on public land unless you have a valid written permission to hunt using that equipment.

Any person who does not hold a valid written permission must not take possession of your firearms, bows or hunting equipment while you are on public land.

## 9. Transportation and storage of firearms

When not actively hunting and not in your immediate possession, all firearms must be stored in accordance with the following provisions:

- firearms must be locked away (either in a locked vehicle or other locked storage device) and not readily accessible
- all reasonable precautions must be taken to ensure that firearms cannot be lost or stolen
- firearms must not be accessible to any person who does not:
  - hold a valid firearms licence or permit
  - have written permission to hunt using firearms.

When transporting or conveying a firearm in a motor vehicle or motorbike:

- firearms and magazines must not be loaded with any ammunition
- firearms must not be visible from outside the vehicle
- all ammunition must be stored in a locked receptacle, separate to the firearm.

## 10. Transportation and storage of bows and other hunting equipment

When not actively hunting and not in your immediate possession, all bows and hunting equipment:

- must be locked away (either in a locked vehicle or other locked storage device) and not readily accessible
- must not be accessible to any person who does not have written permission to hunt using that equipment.

## 11. Hunting areas and exclusion zones

You may only hunt on land that is identified as a hunting area on your DPI hunting map. These maps may also specify the methods allowed in specific hunting areas of the public land area. You must not hunt in areas marked as exclusion zones.

**General hunting exclusion zones:** General hunting exclusion zones are marked on your DPI hunting map as areas where hunting is not permitted.

You are allowed to travel through a general hunting exclusion zone if you hold a written permission. Before doing so, all firearms must be unloaded and ammunition stored separately from the firearm, arrows must be placed in an appropriate container and all hunting dogs must be restrained or confined.

**Total public exclusion zones:** Total public exclusion zones are marked on your DPI hunting map as areas where hunting is not permitted. Signs will be at each road entrance into a total public exclusion zone. You must not enter or travel through a total public exclusion zone at any time.

**Temporary hunting exclusion zones and other sign-posted area:** Temporary hunting exclusion zones may not be identified DPI hunting map. You must always obey all temporary exclusion zone signs and operational signage.

You are allowed to travel through a temporary hunting exclusion zone or other sign-posted area. Before doing so, all firearms must be unloaded and ammunition stored separately from the firearm, arrows must be placed in an

appropriate container and all hunting dogs must be restrained or confined.

### **Infrastructure and asset exclusions:**

Infrastructure and asset exclusions may not be identified on your DPI hunting map.

You must not hunt within 100 metres of any of the following that is located on, or neighbouring public land:

- occupied residence
- dwelling
- fire tower
- building
- radio tower
- transmission tower
- quarry
- pump house.

### **Perpetual and crown leasehold exclusion**

**zones:** Leasehold hunting exclusion zones are marked on your DPI hunting map as areas where hunting is not permitted.

You are not permitted to access, travel through or hunt in a marked leasehold hunting exclusion unless you have written permission from the leaseholder in addition to a valid written permission issued by NSW DPI to hunt in the public land area.

## **12. Day-time hunting**

You may only hunt using a firearm or bow during day-time, being from 30 minutes before sunrise through to 30 minutes after sunset.

You may hunt with a dog during day-time only if 'dogs (day-time)' is specified as an available hunting method on your written permission.

## **13. Night-time hunting (dogs only)**

You may hunt with a dog during night-time only if 'dogs (night-time)' is specified as an available hunting method on your written permission.

When hunting with dogs at night, you must attach a form of illumination to each free-ranging hunting dog.

You must not use any spotlight or searchlight from a moving vehicle when hunting at night.

Firearms and bows are not permitted to be used when hunting with dogs at night and must be locked away and not readily accessible.

## **14. Mandatory use of a Global Positioning System (GPS) device**

You must carry an operational Global Positioning System (GPS) device at all times while hunting.

Minor hunters under 18 years of age are exempt from this requirement as they must hunt in the company of an adult licence holder who must carry a GPS.

Your GPS device must be loaded with current maps that show the hunting and exclusion zones for the area you are hunting, downloaded from the DPI website.

You must be able to show your current position on the device at all times while hunting.

## **15. Blaze orange clothing**

You must wear an item of blaze orange at all times while hunting.

The item must be worn externally on the upper part of your body and must be visible from all



sides. The blaze orange item can be a:

- hat
- beanie
- shirt
- jumper
- jacket
- vest
- buff/ neck warmer.

### 16. Use of vehicles

Unregistered vehicles (including motorcycles and ATVs) must not enter or be used for hunting on public land at any time.

You must not exceed 60 km/h when driving on any sealed or unsealed road, unless otherwise sign-posted.

### 17. Sighting in and target practice

You must not sight-in or target practice with firearms or archery equipment on public land. This includes shooting at clay targets, trees, signs or other objects.

### 18. Tree stands

You must not use a tree stand for hunting on public land.

### 19. Use of drones

You are permitted to use drones to assist in hunting on public land.

All drones must operate in accordance with the Civil Aviation Safety Authority (CASA) licensing and regulations ([www.casa.gov.au/drones/drone-rules](http://www.casa.gov.au/drones/drone-rules)).

Drones cannot be flown within 200 metres of harvesting operation or interfere with any other forestry management operations.

You must not fly within 5 nautical miles (9.26 km) of any fire or other emergency service operation.

You must not disturb or harass any other hunter, public land user or neighbour when using a drone.

### 20. 1080 wild dog and fox poison

1080 wild dog and fox poison baits may be present on public land at any time. Hunters must not interfere with any 1080 baits or equipment while hunting.

Hunting with dogs is permitted at the hunter's own risk.

### 21. Livestock on public land

Livestock (include ear-tagged goats and pigs) may be present in declared hunting areas and must not be harassed, harmed or unnecessarily disturbed.

### 22. Rubbish and toilet waste

All rubbish must be kept in a container or bag when hunting on public land and must take all rubbish with you when leaving.

Toilet waste and toilet paper must be buried to a depth of at least 15 centimetres.

## Hunter's responsibility

It is your responsibility as a hunter to ensure you:

- obtain written permission to hunt on declared public land via the online booking system, available on the DPI Hunting website, before you hunt. If you decide not to hunt, please cancel your booking to allow other hunters access to the forest
- are able to produce a current R-Licence and written permission for the land you are hunting on, for inspection when requested by a DPI Hunting Inspector, NSW Police Officer or authorised Inspector
- understand and comply with all conditions that form part of the written permission to hunt on that public land area, as well as the general licence conditions
- comply with reasonable directions given to you about your hunting by a DPI Hunting Inspector, NSW Police Officer or authorised Inspector.

## Hunt NSW app

The Hunt NSW app allows NSW game hunting licence holders to access and store current hunting maps and their written permissions digitally in one location.

When you're in the field, the mobile app can access online licence holder services so you can:

- book a hunt
- cancel or amend written permissions
- update personal details
- complete harvest returns
- report illegal hunting.

## Changing details on your written permission

At times, you may have to change or amend the details listed in your written permission. You may be taking a different vehicle or leaving one of your hunting dogs at home. Your written permission is a legally binding agreement and all details must be correct.

---

Hunter's tip – You can change your details at any time by logging in to online services through a browser or by using the Hunt NSW app.

---

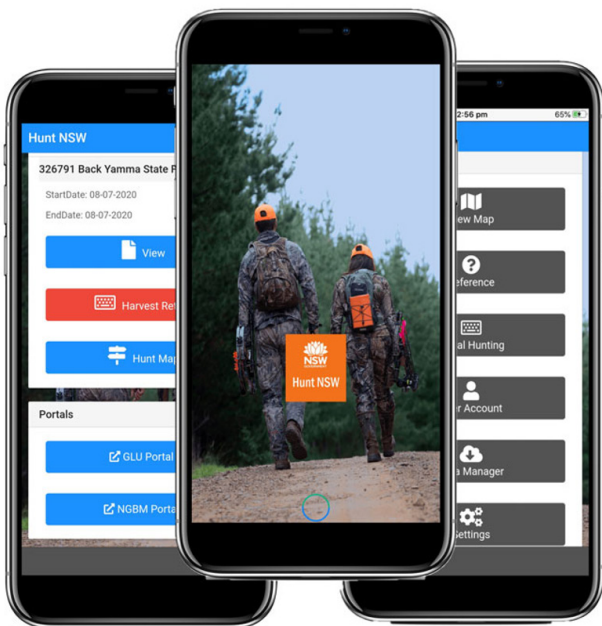

## GPS requirements



A mandatory requirement when hunting on public land is to carry a GPS-enabled device that contains hunting maps downloaded from the DPI during online booking. This is so you can identify where you are at all times. It is a good idea to practice using your device before hunting, as you may be asked by an Inspector to show your location on the electronic map.

If your GPS-enabled device stops working during a hunt, you must cease hunting and return to camp. If the device cannot be fixed, you can no longer continue to hunt.

If you don't own a dedicated GPS device, you can still meet your legal requirements by using the Hunt NSW app or a PDF map reading app on your GPS-enabled device or tablet.

PDF map reading applications work via GPS satellites and will plot your position even if you have no mobile network coverage.

FCNSW releases electronic map files each quarter. You cannot complete a written permission request until you have downloaded the correct map to a GPS-enabled device.

Remember that if you are approached by a hunting Inspector, you will be required to show that your GPS device is loaded with the correct and up-to-date mapping data and can show where you are located.

---

Hunter's tip—If you are using the Hunt NSW app, the maps will automatically populate when you book a written permission.

---

## How does a GPS work?

A GPS works by receiving signals from three to four of the 30 GPS satellites orbiting the Earth. Signals from several satellites create a series of measured distances that let you know where you are on earth by giving you a set of coordinates on your GPS. This is called trilateration.

Each GPS unit has a specific operating system and datum setting that you must be familiar with before using the device.

### General functions of GPS

A GPS unit has a variety of functions within its menu. These can be very useful to the modern hunter. Depending on the device you are using, these functions may include:

- mark a way point
- compass
- track log
- map
- two-way radio
- geotagging
- geocache.



The skill of outdoor navigation is knowing where you are, where you want to go and how to get there. Reading a map, using a map and compass together, and using a GPS to navigate are important skills to have when hunting.

The practice of looking at features on the map and identifying the same features on the ground is being replaced by the use of GPS, but the GPS should never be your only means of navigation and it should never replace the skills of reading a map and using a compass to navigate.

### Using a mobile device and PDF map reading application

PDF map reading applications are available for download onto a mobile device or a tablet and meet your legal requirements to carry a GPS. These applications can read the geo-referenced PDF hunting maps that are produced by the FCNSW and downloaded from DPI. The app uses the GPS function on your mobile device to locate your position on the hunting map.

#### Global Positioning System (GPS)



PDF map reading apps work via GPS satellites and will plot your position even if you have no mobile network coverage. The PDF maps available on the booking system are accurate topographic maps that display your current location on your smart device in real-time.

Each map is displayed in full colour, so you can easily recognise the hunting and exclusion zones within the area that you are hunting.

### Navigating your hunting maps

Public land hunting maps are updated quarterly, and you may need to download new maps before hunting if the quarter has changed. Make sure you always have the correct quarterly map with you.

Once you have downloaded the correct map onto your GPS-enabled device, it's a good idea to study it first and identify areas you wish to hunt. Combining a topographic map with satellite imagery from Google Earth can give you the advantage of locating other areas that have a higher chance of holding game animals.

Understanding and interpreting mapping data is a skill that all hunters should master. The topographic maps supplied are an exact replication of what is physically on the ground.

A topographical map is ideal for navigating in the bush as it shows:



- graphic representation of the Earth’s surface
- land as seen from above
- natural features including water, vegetation, hills and valleys
- man-made objects such as buildings and bridges
- contour lines.

Using a topographical map involves recognising features on the ground, finding those features on the map and then following them to where you would like to go. If you see features on the map, expect to find them on the ground as you travel.

---

Hunter’s tip – Access the DPI hunting maps in PDF or KMZ format by logging into online services through a browser. These extensions are not available through the Hunt NSW app.

---

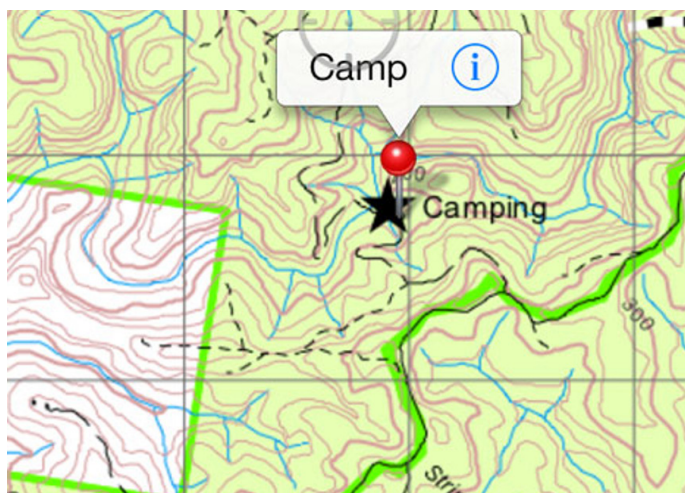

## Contour lines

Contour lines give important information about ground elevation, including how steep the ground is. This information is important, so you can travel safely while moving and hunting. A contour line is a continuous line of elevation or height around the edge of a feature. For example, contour lines close together signify a steep slope. Contour lines further apart signify a gently rising slope.

## Grid coordinates

You can identify a location using the geographic coordinates of latitude (north or south – horizontal lines) and longitude (east or west – vertical lines). A grid reference is used to identify a position on a topographical map. These are described as degrees, minutes and seconds. An example of a geographic coordinate is:

35°26'35" S      149°48'21" E

Latitude and longitude coordinates are shown at each corner on a map. When expressing coordinates, latitude is given first.

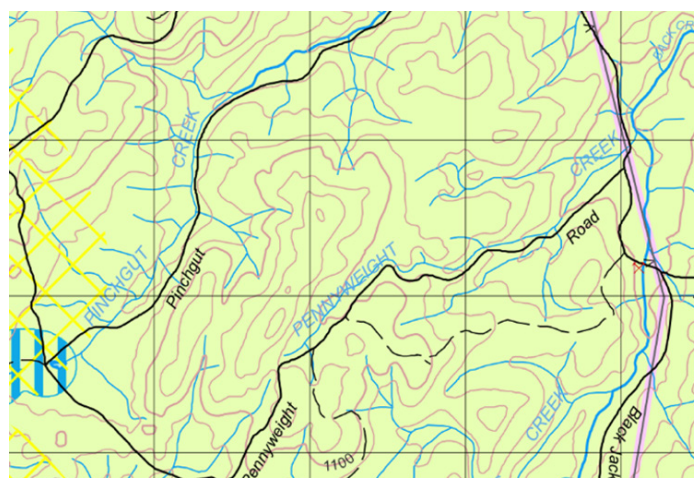

-35.855372, 148.311069



## Eastings and Northings grid references

A grid reference is a simple way of describing a location on the topographic maps supplied with your written permission. The grid squares seen on a map are made up of grid lines called Eastings and Northings. Each Easting grid line is numbered west to east and Northing grid line is numbered south to north.

Eastings are the vertical lines running from the top to bottom and divide the map from west to east.

Northings are the horizontal lines running left to right and divide the map from north to south.

Each easting and northing is numbered on the map margin at 1 km intervals; numbers are used to find a grid reference.

A position on a topographic map is generally shown as a four-or six-figure reference. A four-figure reference will identify which grid square (1 km x 1 km) contains your location. A six-figure reference will specify your position within 100 metres in that grid square.

Let's search the map, and find the six-figure grid reference for Mount Arthur.

- Find Mount Arthur on the map, locate the vertical grid line to the left of the map and record the two-figure Easting number in the top margin of the map: 26.
- Divide the line into tenths, and estimate the value to give you a three-figure Easting number: 266.

- Next, locate the horizontal grid line below your position, and record the two-figure number found in the left margin of the map: 77.
- Divide the line into tenths, and estimate the value to give you a three-figure Northing number: 776.
- Using the Easting grid first, your six-figure grid reference is: GR: 266776.

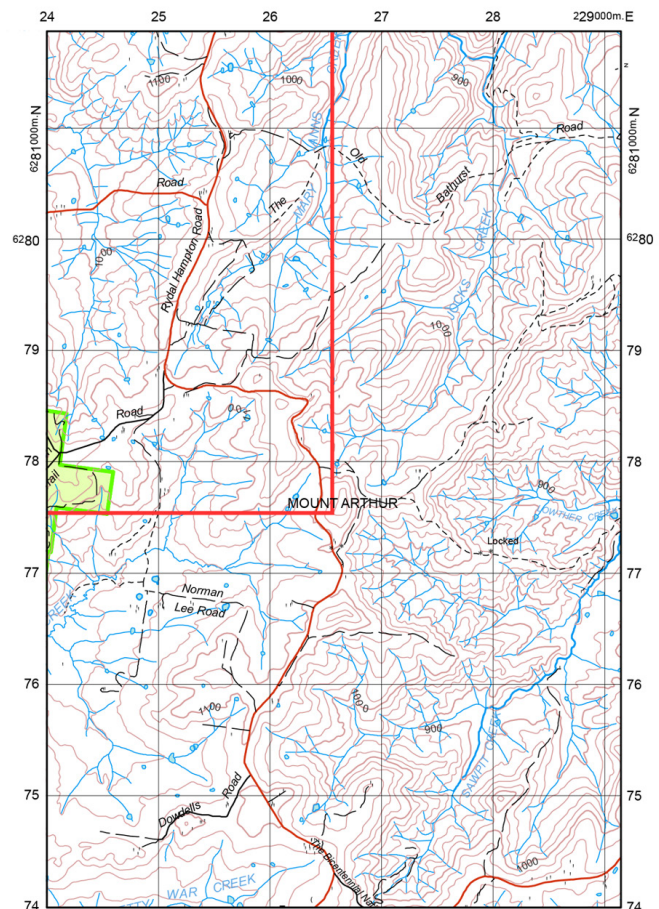



## Exclusion zones



Some public land has areas that are excluded from hunting and are listed under the general written permission conditions.

For State forests, this may be due to forestry operations or safety concerns in the immediate vicinity. Hunters must always be aware of these areas and must be able to correctly identify each zone and understand the allowable activities within the zone.

The GPS maps supplied with your written permission are colour-coded to represent the different zones within the public land area. Hunting exclusion zones have restrictions on the types of activities allowed.

- General Hunting Exclusion Zone
- Total Public Exclusion Zone
- Temporary Hunting Exclusion Zone and other sign-posted areas
- Infrastructure and Asset Exclusions
- Perpetual and Crown Leasehold Exclusion Zones

There is a legend at the bottom of each map that explains the different hunting and exclusion zones. It is your responsibility to be able to identify these correctly.



## Hunters setting a good example

Hunters need to be aware of how their actions can impact the quality of their surroundings. You should always aim to leave the environment better than when you first arrived.

Natural habitats and ecosystems can be extremely sensitive to human activity. All types of wildlife and native plants rely on the quality of their environment in order to thrive and reproduce.

These simple rules help maintain public hunting areas and meet community expectations for the behaviour of ethical hunters:

- take all your rubbish with you
- do not leave spent cartridges or shells behind; they do not easily decompose
- always drive on designated tracks
- always drive slowly and safely, and obey the 60 km/h speed limit on forest roads
- leave native animals, plants, flowers and non-camping areas as you found them; animals rely on these for food and shelter

- do not leave any food items or their packaging behind
- always dispose of harvested animal carcasses thoughtfully and away from water bodies
- at a minimum, cover animal waste and offal with dead vegetation and rocks.

## Other hunters

Holding an R-Licence gives you authority to hunt on public land, subject to meeting all legal obligations that are attached to your R-Licence and written permission.

Every R-Licence holder has the same authority. While hunting, if you do happen to come across another R-Licensed hunter, you should always be courteous and respectful. Many hunters are happy to help and might even offer you some friendly advice.

Even when not hunting, you can observe the following rules to show respect for both your fellow hunters and the opportunity to hunt public land through this program:

- never book a forest if you don't intend to hunt
- if you do have a booking and your plans change, cancel your booking to allow other hunters to access the forest
- don't camp in prime hunting habitat, and don't camp too close to other hunters
- if you are hunting in the same area as another hunter, observe all safety precautions or move to another location.

However, if you come across hunters who are not wearing blaze orange or who you suspect may not have the correct authority, report the incident to DPI Hunting via online services or through the Hunt NSW app.

---

Hunter's tip – If you cannot make a hunt that you have booked, you can cancel or amend your booking or lodge an early harvest return if the permission has begun.



## Other forest users

All land declared for public land hunting is also open to the general public. Chances are you won't encounter a non-hunter on public land. However, some forests can be popular with other recreational users at certain times of the year.

It is important to remember that some non-hunting forest users may not be aware of NSW public land hunting regulations. Non-hunting forest users may include:

- forestry staff
- horse riders
- motorbike riders
- campers

- hikers and bushwalkers
- fishers
- mushroom pickers
- photographers
- bird watchers
- students
- government rangers and other officers
- adjoining land owners
- Crown land leaseholders.

Licence holders should remember that the presence of a firearm, bow or hunting dogs may appear very intimidating. You should always:

- immediately unload your firearm, and point the muzzle in a safe direction
- place the firearm in the shoulder carry position, and leave the action open or broken
- make sure your bow is safe, and all arrows are quivered
- restrain any dogs by placing them on a leash or locking them in the dog box on your vehicle
- remove any face mask or coverings
- introduce yourself politely if the situation allows
- be respectful of the non-hunting forest user; they have as much right to be in the forest as



## Hunting with non-hunting companions

At times, a friend may wish to accompany you on a hunt; however, they don't hold an R-Licence. Having them join you is great way to introduce people to hunting and another person also adds to your safety.

When you take a non-hunting companion with you, there a few things you need to be aware of. A non-hunting companion must not:

- assist in the hunting of game or feral animals by the licensed hunter
- be in possession of firearms, bows or any other equipment used for hunting, including carrying any hunting equipment on behalf of a licensed hunter.

However, non-hunting companions may assist a licensed hunter to handle and carry harvested game animal carcasses.



## Forestry infrastructure

All State forests are working forests. Timber is sustainably harvested, offering prime habitats for a variety of animals. These trees are a valuable natural resource and should never be shot at. Projectiles and arrowheads lodged into the timber can cause serious damage to harvesting and processing machinery.



Forest signage is there to give you important information about the forest for your safety and the safety of other forest users. It is illegal to shoot at any signs. Not only you are damaging important infrastructure but also you could be firing your gun at a dangerous angle.



## Forestry signs

There are a number of forestry signs that hunters will come across while hunting on public land. It is important that you are familiar with these signs, and you must obey them at all times.



These signs provide information on the forest activities and restrict access to parts of the forest when necessary to ensure everyone's safety.

There are over 100 designated visitor sites that are sign posted in NSW State forests. These include:

- picnic areas
- campgrounds
- walking trails.

## Operational signs

Forest operations include timber harvesting, site preparation and road constructions. A range of signs are used to restrict access to these areas and ensure public and work safety.

The following signs will be displayed if public access is restricted:



You may encounter awareness and safety signs and heavy vehicles in working forests. You may also see signs that tell you how to communicate with other vehicles on forest roads.



## Hunting signs



Hunting signs advise the particular forest is available for hunting and reinforce that both a written permission and an R-Licence are required before entering the forest to hunt.

These signs will be placed at key entry points to each state forest available for hunting.

Sometimes, there is a need to exclude an area of a declared State forest from hunting. This may be because Forestry personnel are working on a site or there is a recreational event taking place.

When an area is excluded, this sign is placed to alert hunters and the general public that the area is excluded from hunting and that other people may be in the area. The sign will have extra information in the comment section regarding contact persons or the dates that apply to the exclusion.

These exclusion zones will also be identified on the maps provided with your written permission and also on your GPS device. However, an area may be excluded to hunting at short notice and not appear on the map. In this instance, you must always obey the signage as a minimum.

Some forests with high populations of wild dogs and feral pigs may participate in 1080 poison baiting programs. When 1080 is being used, FCNSW will clearly sign post bait locations. Regular baiting programs will be listed on your written permission. At times, hunters may receive an advisory from DPI Hunting through email or SMS about a baiting program that does not appear on your written permission.

Hunting with dogs may still be allowed during 1080 poison baiting programs, and it is your responsibility to keep your dogs safe and away from the marked baiting areas.

---

Hunter's tip – At times, a baiting program will not be marked on a map, and you may not receive a DPI advisory. In this instance, you must comply with all baiting signage.

---

## Respect neighbouring private properties

Most public land borders private property, and you may see a variety of wildlife and game animals over the fence. However, private landholders have the right to privacy and that right must be respected by R-Licensed hunters. You might even see 'no hunting' or 'private land' signs on fences and gates.

It is always tempting to approach neighbouring properties to ask for permission to hunt. Keep in mind that many people may have already door knocked adjoining properties, so a cold approach might not be the best strategy. Unless you have a personal introduction to the landholder, it's recommended that you do not door knock any adjoining properties.

Biosecurity obligations require hunters to obey all signage before entering any property. If you do see a biosecurity sign, you must call the property owner to obtain the correct entry procedures.



Hunting fringe country and the borders of public land always poses the risk of a wounded or poorly shot animal running onto land that you don't have permission to enter. Before taking a shot at any animal, you must consider all the risk factors, and if you have any doubts, do not take the shot!

If a wounded animal does enter private property, you must obtain permission from the landowner or manager to recover the animal. Entering land without permission is trespassing.

## Fires on public land

Campfires serve many purposes and add to the social benefits of the hunt.

When searching for suitable timber, only use dead, fallen trees that are dry, as wet timber will smoke and smoulder. Never cut down trees or branches to use in your fire.

While campfires are great, they can also be dangerous if they are not extinguished properly. You must never leave any fire unattended and it must be totally extinguished before you leave camp. Best practice is to:

- let the fire burn out as much as possible, preferably to coals or ash
- separate any large logs from the fire using a thick branch or shovel
- slowly sprinkle water onto the fire and embers
- add water until the fire is out and the embers are no longer glowing red
- not bury the fire; buried coals can retain a lot of heat and can reignite many hours later

Before leaving camp, check that the fire is out and there is no remaining heat; adding water is the best way to cool the area.



---

Hunter's tip—General written permission condition 7 requires you to check whether there are any total or solid fuel fire bans in place before your hunt.

---



## Balloted hunting

Hunting opportunities in some very popular forests are accessed through a ballot system. This gives everyone a fair and equal chance of accessing forests that would otherwise be very difficult to book.

Balloted hunting is generally applied during the peak hunting months of March and April, and hunters must comply with all terms and conditions. Registrations are free of charge and available online.



## Why are some forests closed to hunting?

Forestry Corporation may open or close forests to hunting at different times so they can manage their commercial logging activities, conduct pest management programs such as dog baiting or because of work, health and safety concerns. Closures are put in place for your safety and the safety of other forest users. DPI Hunting works closely with Forestry Corporation to review declared hunting land for R-Licence holders. Forest closures are a regular part of the public land hunting program.



## Working with hunting Inspectors

At times, you may encounter an authorised Hunting Inspector. They frequently patrol private property and public lands to ensure licensed hunters are following the rules and conditions of their hunting licences, their permits to hunt and to identify any activity from illegal hunters.

Hunting Inspectors offer advice to help hunters understand their obligations relating to game hunting laws. They also enforce regulations that protect hunter access to public land and ensure that hunting is conducted in a safe and responsible manner.

If you are approached by an Inspector in the field, you should always:

- unload your firearm, and ensure your muzzle is pointed in a safe direction
- restrain any dogs you are hunting with
- make your bow safe, and place any arrows in their quiver or holder
- produce your NSW game hunting licence when asked

- produce your firearms licence if asked
- produce your written permission and GPS-enabled device; you must demonstrate that the device is working and is loaded with the current version of your hunting maps
- allow Inspectors to check any game animals or game birds that you have in your possession
- comply with any direction given by an Inspector, including to stop your vehicle; failing to do so is committing an offence

Inspectors have the power to seize anything connected to a game hunting offence; this may include firearms, bows, hunting-related equipment, electronic devices, vehicles, dogs or harvested animals that have been used in or evidence of a hunting offence.

It is a serious offence to obstruct, hinder, impede, assault, threaten or intimidate an Inspector during the course of their duties.

Remember that DPI Hunting Inspectors are there to ensure your safety, maintain hunting standards and target illegal hunting activity.



Department of Primary Industries

**Harvest Return Entry**

Written Permission Number	<input type="text" value="354833"/>
Area Description	<input type="text" value="Coolangubra State Forest"/>
Written Permission Date From	<input type="text" value="08/12/2020"/>
Written Permission Date To	<input type="text" value="08/12/2020"/>
Licence Number	<input type="text" value="0"/>
Licence Holder Name	<input type="text" value="Test Customer"/>
Address	<input type="text" value="PO Box 2506 ORANGE, NSW 2800"/>
Days Spent Hunting *	<input type="text"/>
Night Pig Dog Hunting *	<input type="radio"/> Yes <input type="radio"/> No
Number of Nights Spent Pig Dog Hunting	<input type="text"/>
Number of Pigs Taken at Night with Dogs	<input type="text"/>

[Identify hunting methods](#)

## Harvest returns

After each public land hunt, you will be required to submit a harvest return, even if you did not see or did not harvest any animals.

Harvest returns provide useful information about the success of public land hunting, how hunters are helping in the control and management of pest species and are used to compile species reports that tell hunters which species may be present in each forest.

When you are completing your harvest return, it is important to report the results of your hunt honestly. The success of public land hunting and various private land management programs depends on the NSW DPI receiving factual information. Without it, it is difficult to demonstrate the important role hunters play in pest and wildlife management.

## UNIT 6: HUNTING ON PRIVATE LAND



### Introduction and learning objectives

Access to hunting on private land is a privilege that must be taken seriously. The landholder trusts that you will act in a safe, ethical and responsible manner. Acting irresponsibly can damage the relationship you have with the landholder and will always result in loss of access. It may also result in the landholder revoking access to all hunters on their property now and into the future.

The unit objectives are:

- understand your responsibilities when hunting on private land
- practice safety when hunting from a vehicle with a spotlight
- hunt from a tree stand safely
- understand the Native Game Bird Management Program
- comply with your biosecurity obligations.

Holding an R-Licence, even when hunting on private land across Australia, gives landholders confidence as they know that you are covered

with third-party public liability insurance. The high standards expected of you as a licence holder on public land should also be applied when you are hunting on private land.

### Respect your access

Hunters must always have the correct permissions before hunting on any type of land. For private land hunting, NSW law requires you to have permission, or express authority to hunt, from the landholder or manager.



If you have access to private land, always obey any special considerations the landowner may give to you when hunting on their property, such as whether you or not you may use a dog. It is their right to impose restrictions to hunters, and you must obey them if you wish to maintain their permission to hunt on their land. Also be mindful that the landowner gave you, and not your friends, permission to hunt. If you want to bring companions on a hunt, you must notify the landholder ahead of time, and get their permission to do so.

While hunting, treat the land as if it were your own. You wouldn't like hunters on your property leaving spent cartridges lying around, driving through your



crops, leaving fences or gates in poor condition or shooting in the direction of your buildings or family, so don't do it to others.

At the end of your hunt, stop by the house, and thank the landowner in person. If you harvested game, offer them a share of the harvest. If you follow all these tips, you should be allowed to return for future hunts.

### How hunters help reduce illegal hunting

The presence of licensed, legal and responsible hunters is the best deterrent to those who intend to do the wrong thing. Licensed hunters tend to pursue the same animals and hunt in the same parts of the property as those targeted by illegal hunters. And there is every chance that licensed hunters and illegal hunters will cross paths. Licensed hunters are extra eyes and ears on the ground. They can gather information on illegal hunters that assists in investigations and prosecutions.



Sometimes it is difficult for non-hunters to distinguish between licensed, responsible hunters and illegal hunters who do the wrong thing. This may be due to a lack of knowledge or is simply that non-hunters have not been given the right information.

Illegal hunting and trespassing put considerable strain on rural communities, landholders and enforcement agencies.

Illegal hunting can occur at any time of the day but is mostly committed at dusk and dawn when animals are most active or at night when the offenders can move about under the cover of darkness.

### Signs of illegal hunting



General signs of illegal hunting include:

- spent cartridges, signs with bullet holes, dead or injured animals with gunshot or other trauma wounds, arrows left in paddocks, vehicles with their number plates missing or obscured, stray hunting dogs often without a microchip or a collar without an identification tag
- any firearms use on adjoining public land at night — licensed hunting using firearms on public land is only permitted during daylight hours
- use of firearms under spotlights on the property you are hunting on — illegal hunters often use spotlights at night

- the harming of native animals — it is illegal to harm native animals without the correct permits issued by the NSW Government.

Hunting Inspectors may also enter private property in certain circumstances related to hunting offences.

---

Important – The simple message is: the more licensed and legal hunters on private land = less illegal hunting activity.

---

## Shut the gate on illegal hunting

DPI Hunting and NSW Police Force work closely with rural communities in NSW to assist them to detect and deter illegal hunting. The Shut the Gate on Illegal Hunting program is part of a wider program to shut the gate on rural crime in NSW.

Specifically, the aim of the program is to

- provide information on illegal hunting to the community
- empower communities to report illegal hunting every time it occurs and in a timely manner
- provide program material to assist landholders detect and deter illegal hunting
- assist the DPI Hunting and NSW Police to address illegal hunting through enhanced intelligence capabilities and joint operations.

**Private property**  
**NO HUNTING WITHOUT PERMISSION**  
**Shut the gate on ILLEGAL HUNTING**

Report illegal hunting at **Crime Stoppers** on  
**1800 333 000** or [www.crimestoppers.com.au](http://www.crimestoppers.com.au)

For more information go to  
[www.dpi.nsw.gov.au/hunting](http://www.dpi.nsw.gov.au/hunting)

NSW Department of Primary Industries NSW Police Force

Help Shut the gate on illegal hunting by reporting illegal activities you see while hunting. Useful information includes:

- date, time and place of the offence
- details about the offenders
- vehicle type and registration
- type of illegal activity.

Help address illegal hunting by reporting it to DPI Hunting via online services or through the Hunt NSW app.

---

Important – For your safety, do not confront anyone that you suspect is committing a crime.

---

## How hunters help control pest and wildlife species

Hunting is an important tool in pest animal control. Every introduced species causes at least one form of environmental damage to every habitat they are found in.

Whether it is damage to a resource such as a pine plantation or an agricultural crop, through the spread of disease or by competing with livestock, hunters are helping by removing these problem animals safely and humanely.

It is now widely recognised that the complete eradication of pest animal species is physically and economically impossible. It is accepted that in order to achieve best results, pest management programs need to combine multiple pest control techniques and be carried out with a consistent approach.

Licensed responsible hunters in NSW can demonstrate an even greater role in pest management by assisting landholders and managers in the control of pest animals that spread disease and compete with domestic animals and native wildlife.

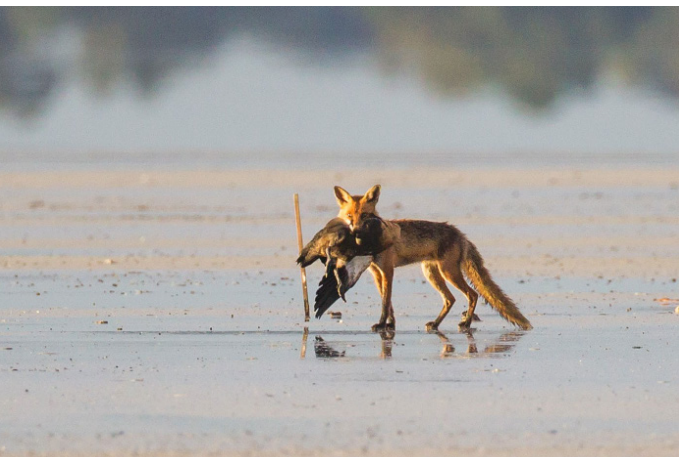

## Respect private property

Remember, you are a guest on the landholder's property, and as a guest you must be respectful to your host.

Showing respect doesn't end with the landholder. You should also respect the property and livestock as well as all farming and production.

You can show respect to the property and the landholder by following these best practices:

- always give the landholder sufficient notice of when you intend to hunt on their land, including times and duration
- obey all the landholder rules at all times
- treat the property as if it were your own
- do not leave any rubbish on the property, including empty cartridges and ammunition
- leave all gates as you found them
- extinguish any campfires
- do not drive through paddocks or crops, and always stay on the tracks
- do not drive over tracks in wet weather, as this can cause massive damage; it's best to hunt on foot in wet weather
- never shoot towards houses, building or stock animals
- never shoot across roads or fence lines
- stop hunting immediately if things happen to go wrong, and explain the situation to landholder



- always thank the landholder after your hunt, and notify them of any issues you may have encountered
- always offer to share your harvested animals or fish with the landholder.



### Biosecurity on private land

The *Biosecurity Act 2015* applies restrictions on the transportation of biological matter. This can include animals, plants, diseases, soil and other risks. Every person has a biosecurity duty under this act, including hunters.

Many properties have biosecurity management plans that restrict the movement of people, animals and goods under provisions of the *Biosecurity Act 2015*. Hunters should discuss any specific biosecurity requirements with landholders before they enter their properties and observe all signage. This may include phoning the landholder before opening any gates.

It is good practice to wash down your vehicle before entering and after leaving a property with a biosecurity management plan. Make sure your boots and hunting clothing do not harbour any

seeds, soil or plant material and always report any sick livestock or wildlife to the property owner.

In Unit 2: Hunting laws in NSW, we discussed where to find legislation. Revisit this unit if you need to find more information about hunting laws.



### Native and protected animals

Licensed and responsible hunters provide an important service to private landholders and the general community by safely and humanely removing problem wildlife species. Often this service includes culling both introduced and native species.

Harming of native wildlife is highly regulated to ensure that humane welfare principles and high ethical standards are applied and that the activity does not encroach on commercial harvesting industry administered by the NSW Government.

The harming of native wildlife can only occur when the landholder is appropriately licensed, and hunters abide by the regulations specific to each species.



Landholders that are impacted by native wildlife should contact the NSW National Parks and Wildlife Service to obtain more information about managing native animals on their land.

### Native Game Bird Management Program

Although there is no recreational hunting of native game birds in NSW, landholders can sustainably manage native game birds that are impacting their agricultural production with the assistance of licensed hunters through the Native Game Bird Management Program (the program).

Hunters wishing to take part in the program must hold a current NSW game hunting licence and have passed the Waterfowl Identification Test. Native game bird hunting in NSW is for 'sustainable agricultural management purposes' only. This means:

- those activities that contribute positively to farm, regional and the State's productivity and economy; that adaptively manage and enhance biological and physical resources and support the State's regional and rural communities.

Private agricultural landholders must demonstrate that their agricultural activities are being impacted by problem native game birds. Both landholders and hunters need to hold a licence to take part in the program.

- Landholders require a Native Game Bird Management (owner/occupier) Licence.
- Hunters require a restricted or general game hunting licence that is endorsed for the program.

As the program operates on private land only, native game birds may be hunted at night but only in the immediate vicinity of a planted crop. A light of sufficient brightness must be used that enables hunters to clearly see and identify the target species.



## Waterfowl Identification Test

Hunters must pass the Waterfowl Identification Test (WIT) before they can be endorsed for the program. The WIT assesses your ability to identify game and non-game bird species.

Anyone wishing to hunt native game birds in NSW needs to hold a WIT certification number and have this number added to their NSW game hunting licence. When a licence is updated to include the WIT number, the holder is endorsed and may participate in the program.

The hunting licence requirement includes landholders who intend to hunt or shoot-to-scare native game birds themselves and must be held in addition to their management licence.

---

Hunter's tip – A game hunting licence endorsed for the program will have GB printed on the back of the licence card.

---

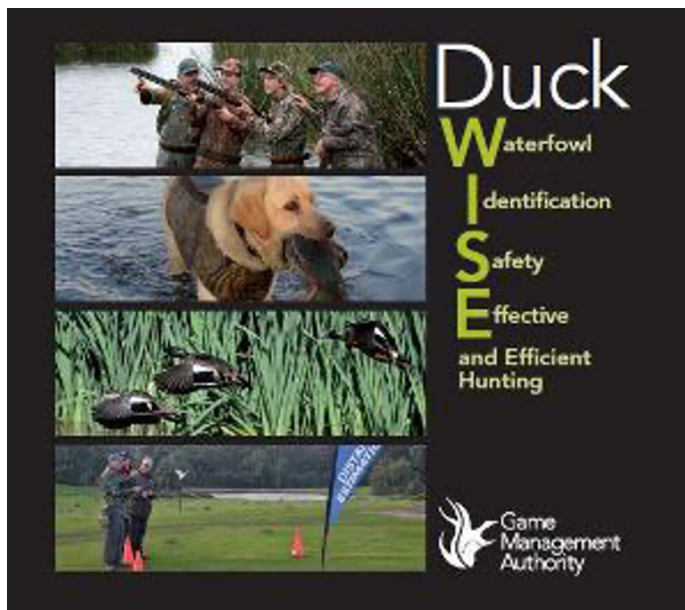

## State-wide harvest quota

Before native game birds may be harvested on any land in NSW, there must be an available quota. This ensures the longevity and sustainability of native game bird management.

DPI sets an annual state-wide quota of native game bird species that may be sustainably harvested under the program. Once the quota is set, an allocation of species and maximum harvest numbers are set for each property covered by a management licence.

DPI must use the best scientific information available on the estimated regional populations of native game birds when determining the state-wide quota. This ensures that only the most robust and sustainable populations of native game birds can be hunted each year.





## Property allocations

Individual property allocations are the total number of each species of game birds that can be harvested on that property. Each year, DPI assesses the allocations requested by landholders for each of their licensed properties and determines a sufficient allocation based on current and historical impacts as well as previous harvest reporting.

Property allocation information and harvest reporting is conducted through an online portal, available to endorsed licence holders through DPI online services.



## Native game bird species

Native game bird species that may be allocated a harvest quota as part of the Native Game Bird Management Program include:

- Australian Shelduck or Mountain Duck
- Australian Wood Duck or Maned Duck
- Black Duck or Pacific Black Duck
- Blue-winged Shoveler or Australasian Shoveler

- Chestnut Teal
- Grass Whistling Duck or Plumed Whistling Duck
- Grey Teal
- Hardhead Duck or White-eyed Duck
- Pink-eared Duck
- Water Whistling Duck, Wandering Whistling Duck or Whistling or Wandering Tree Duck.

Currently, there is not enough scientific evidence to allow a quota for other species of native game bird species.

### Express authority

Before you can hunt native game birds in NSW, licensed hunters must obtain 'express authority' to hunt from the owner or occupier of land that is covered by a Native Game Bird Management (owner/occupier) Licence. You must obtain their authority before hunting native game birds on each licensed property.

Landholders may be asked to verify permissions granted to certain hunters when asked by a hunting Inspector.

---

Hunter's tip – Revisit Unit 4 - Animal identification, wildlife management and the welfare of hunted animals if you need help identifying native game birds.

---

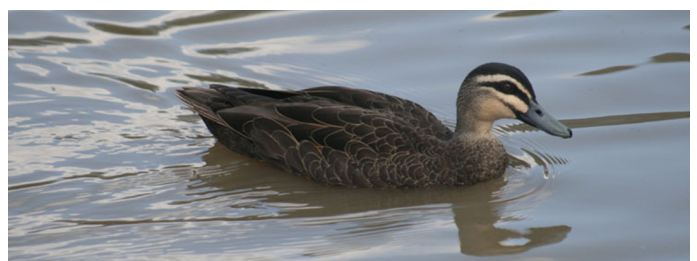

## Using the Native Game Bird Hunter Diary



The Native Game Bird Hunter Diary assists hunters to comply with the conditions of the program.

It is mandatory to record the property's available species allocation before you hunt, and record your harvest figures after your hunt.

Accurate records and reporting to DPI are important to maintain the integrity and future of the program.

---

Hunter's tip – You can access a digital version of the hunter diary from the DPI website.

---

## Spotlighting safety

Hunting with a spotlight is only permitted on private land with permission from the landholder.

Shooting under a spotlight is a necessary task that assists landholders with pest animal control. Using a spotlight at night to locate animals and hold them in the light is a very efficient and effective means of reducing problem animals. When shooting in a team, using a driver, a shooter and a spotlight operator, is an effective method that gives the shooter more time to:

- assess if a safe shot presents itself
- positively identify the target
- ensure they deliver an accurate and humane kill shot.

---

Important – Spotlights are not permitted on any public land.

---



## Hunting from a vehicle with a spotlight

Hunting from a vehicle with a spotlight allows you to cover large tracts of land that you would not be able to cover on foot in the same time. Also, if the target species happens to frequent a preferred crop that is several kilometres away from your base or camp, the use of a vehicle also becomes very time efficient.

Spotlighting from a vehicle at night has associated risks that all hunters must be aware of. You must always practice the following safety precautions:

- notify the landholder of your intention to hunt under spotlight if they have approved its use
  - know the hunting environment extremely well; during daylight hours, familiarise yourself with the hunting area before you begin to spotlight
  - drive slowly and stay on designated roads and tracks
  - practice safe driving to reduce the risk of the shooters falling out of the vehicle
  - do not spotlight in a group of more than three people
  - ensure the shooter is always positioned in front of the spotlight operator
  - ensure the spotlights and gun-mounted lights are bright enough to positively identify your target
  - never shoot at a moving animal; all shots must be taken at a stationary target animal
  - do not shoot if you are unable to clearly identify your target
- make sure the vehicle has a firm, stable and safe rest to shoot from
  - make sure you have a safe backstop; never shoot over a crest or a hill
  - be extremely careful of ricochet when shooting across hard ground or water
  - fit a solid bipod to your rifle
  - unload your firearm, and ensure it is safe before collecting any harvested animals
  - never fire at a pair of eyes or a reflection
  - ensure you pay particular attention when shooting close to fences, boundaries, roads and tracks
  - never attempt to take a shot if there are any safety concerns.

---

Important – Vehicle rollovers while spotlighting are the highest reported hunting incidents in NSW.

---





## Tree stands on private land

### Important

General written permission condition 19 prohibits the use of tree stands or elevated stands on public land.

Before you set up a tree stand (a type of an elevated stand) on private land, always seek permission from the landholder.

### Importance of safety

Using a tree stand or an elevated stand gives you the advantage of a bird's-eye view over your hunting area. While they offer certain advantages, they also come with some serious safety concerns that all hunters need to be aware of.

It is always wise to test the stand to ensure it is secure and safe to use before climbing into it.

### Using a fall arrest system/full-body harness

Hunters should always wear a fall arrest system when hunting from an elevated stand.

If you do happen to fall from a tree stand, these systems are designed to stop you from hitting the ground and to prevent serious injuries.

### Types of tree stands

Here are the most common types of tree stands:

- homemade or permanent tree stand
- fixed or hang-on tree stand
- self-climbing stand

- ladder stand
- tower stand.

A hunter should never carry hunting equipment when climbing a tree stand. Instead, retrieve all equipment using a haul line once you are safely in place. Before you go hunting, you should always let others know:

- your exact hunting location
- where your tree stand is located
- when you plan to return
- who is with you.

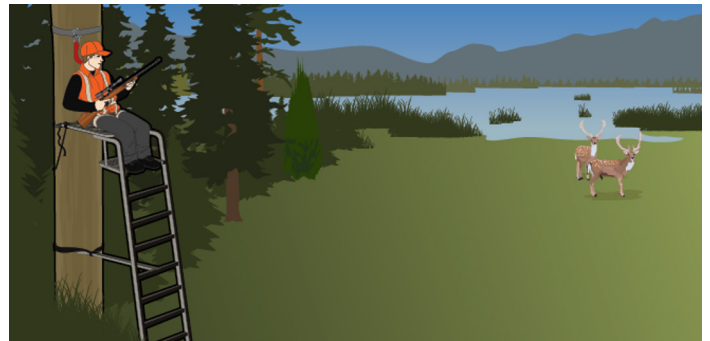

## UNIT 7: OUTDOOR SAFETY AND SURVIVAL



### Introduction and learning objectives

Acting in a safe manner while hunting means that everyone will return home safely. While there are many different methods and styles of hunting, the safety concerns remain the same. Every hunter should be aware of their skill level and capabilities as well as know their physical limits and respect those limits when they are out in the field.

The unit objectives are:

- plan your hunt and consider the most common risks
- assemble your backpack with the right safety items
- practice the S.T.O.P. technique, and know the Big 3 of survival
- administer basic first aid.

A safe hunter takes time to prepare and to practice using all their equipment before going out into the field for a hunt. Safety awareness should become second nature to hunters who consistently practice safe hunting.

Even though hunting and shooting are very safe activities, once a bullet or arrow is fired, it can never be undone.

### Planning your hunt

Planning for your hunt should happen well before the vehicle is packed with your equipment. Making a plan is simple. Write down details such as:

- location where you will be hunting
- names of your hunting partners
- contact numbers
- route you will be taking
- time you will leave
- time you expect to return.

Leave this plan with a family member or friend, and keep a copy in your vehicle. Knowing the weather conditions for the hunt, terrain of the land, type of animals being hunted and what equipment you will need are other factors that will help you prepare for the hunt.

Once you've made a hunting plan, it is important to stick to that plan. For example, once you are out in the bush, do not suddenly decide to hunt in another area that was not indicated in your hunting plan. If you do and something should happen to you, emergency crews will not know where to find you.

Also, if you decide to extend the length of your hunt without first telling your contact person, they might panic and contact emergency services unnecessarily.



## What to pack

A good hunter prepares for every scenario and is ready for an emergency before it happens. Here are three key safety items you need to assemble while you are planning and packing for your hunt.

1. Basic survival kit.
2. Hunting pack.
3. First-aid kit.



## Packing for your hunt: basic survival kit

All hunters should carry the following items every time they head into the field — even if it’s just for a few hours. This kit should be separate from your other items and easily accessible in the event of an emergency.

- Two large garbage bags and at least 10 metres of rope to build a shelter.
- Fire-starting equipment:
  - waterproof matches, a magnesium fire starter or strike-anywhere matches sealed in a plastic bag
  - petroleum jelly inside cotton balls: they catch fire very effectively and are very useful for starting a fire if there is little dry wood to be found; keep cotton balls in a small ziplock bag.
- Signalling devices such as a plastic whistle or signalling mirror.
- Spare compass and map of the area.
- Bottled water.
- A small quantity of high-energy food (i.e. granola bar, trail mix, nuts, etc.).





## Packing for your hunt: building your hunting pack

Putting together a pack with useful items is an excellent way to prepare for a hunting trip, especially longer trips in unfamiliar territory. In addition to your basic survival kit, your hunting pack (backpack) should include all of the following items at a minimum:

- first-aid kit
- a GPS-enabled device
- personal locator beacon
- knives and a sharpening kit
- sunscreen
- a torch with spare batteries
- tissues
- food and snacks for the day
- a length of string, rope or cord
- blaze orange flagging tape
- a map of the area and compass
- rain gear
- sunglasses
- a large sheet of plastic
- soap or sanitising lotion
- parachute cord
- prescription medicine (where required)
- spare glasses (where required)
- a backpack to carry all the items.

---

Hunter's tip—Firearms hunters should also carry a gun maintenance kit. See page 119 in Section 2, Category 1: Firearms for details.

---



### Packing for your hunt: first-aid kit

A good first-aid kit is an essential part of a hunter's equipment. These are the basic items that should be in your hunting first-aid kit:

- two pairs of disposable gloves
- sterile dressings to stop bleeding
- antibacterial wipes to disinfect cuts
- antibacterial creams or dressings to prevent infection
- adhesive bandages in a variety of sizes
- bandaids
- an elastic snake-bite bandage
- tweezers and a needle

- pain relievers
- prescription medications you take every day (check expiration dates on medications)
- eye-wash solution to flush the eyes or as a general decontaminant
- first-aid handbook or guide.



### Personal locator beacons

Hunters travelling to remote forests or spending multiple nights in wilderness areas should always carry a personal locator beacon (PLB). Many areas of NSW do not have mobile phone coverage, and in the event of an emergency, there is no way to call for help.

When activated, a PLB works in a similar way to a GPS. The international search-and-rescue satellite system listens for distress signals transmitted from earth. When it hears a signal, it notifies the nearest ground station with the coordinates of the PLB.

Search-and-rescue authorities commence recovery operations as soon as possible. If you have registered your PLB online and you keep your

**Personal Locator Beacon**



hunting trip details up to date, search operations can begin much sooner.

Rescue times can vary considerably for a number of reasons, so make sure you have your survival pack with you.

When you hear or see search-and-rescue personnel, use your torch or mirror or signal fire to pinpoint your location.

### What to do in an emergency

In an emergency, the first step is to remain calm. Gather your thoughts, and assess the situation. Ask yourself a few questions.

1. Is someone seriously injured and in need of urgent medical attention?
2. Is your life in serious danger?
3. Have you just witnessed a serious accident?

If you answer yes to any of these questions, find an area with phone reception and immediately call 000 for help, or activate your PLB.

If you cannot get in contact with anyone, you need to be prepared to survive outdoors until help arrives.

## Camping safety

Most public lands open to hunting have designated camping grounds. These areas have been selected to minimise human interference on the local environment. If camping grounds are not available, you might have to find a suitable spot to pitch your tent or roll out your swag.

These tips will help you select the right camping spot:

- always use a designated campsite rather than creating a new one
- if you are using a camping ground, be considerate of other hunters and campers
- only camp on hard ground or sandy soils; avoid damaging soft soils or vegetation
- camp at least 20 metres away from any waterway
- be aware of flash flooding, and always camp on high ground
- avoid tying anchor ropes to trees, as this can damage their bark
- park your vehicle as close as possible to formed tracks and roads to minimise damage to the forest floor
- never camp under trees that have loose, dead or overhanging branches
- securely store all your hunting equipment when not using it
- take all rubbish away with you, even if it's not yours
- do not contaminate waterways by disposing of detergents, soaps and toothpaste
- human waste should be buried at least 15 centimetres deep and at least 50 metres away from the camp and waterways
- try to use a fuel stove for cooking; check for solid fuel fire bans and if building a fire, keep it small and ensure you do so in a cleared area where the embers cannot start a bushfire
- only use dead, fallen wood for campfires; do not cut down any standing trees or vegetation, even if they are dead; animals rely on these for shelter
- do not use your fire to burn rubbish; plastics release toxic gases when burned
- do not feed any wildlife that may come near your camp; human food can be harmful and cause them to become dependent on an easy food source.





## What should I do if I get lost?

Your GPS device and hunting maps ensure that you always know where you are. However, there is always a risk of you or another forest user becoming lost. GPS malfunctions or being caught in a sudden storm might prevent you from getting back to camp especially when hunting in an unfamiliar area. If you don't feel comfortable hunting in an area, or if you feel unprepared, do not take the chance.

Hunting is a safe activity when conducted legally, ethically and with careful awareness of each situation. By following some simple guidelines, you can reduce the chance of getting lost in the great outdoors.

When a person gets lost, a change takes place both mentally and physically. When you're lost, it is important to remain calm because the most powerful tool you have is your brain.



## S.T.O.P.: stop, think, observe, plan



### **Stop Think Observe Plan**

Sometimes hunters get lost despite their most careful precautions. But if they are adequately prepared, the misadventure will not last very long.

The first action you must take is to stop and sit down. The word S.T.O.P. is an acronym used in survival.

**S: Stop** and sit down. Keep a positive mental attitude.

**T: Think** about your surroundings. Could you find your way out, or are you going to spend the night?

**O: Observe** what is around you. Can you hear vehicles? Can you hear farm animals or farm machinery? Can you see radio towers or logging roads? Use your senses to find out where you are, and always refer to your hunting maps.

**P: Plan** what you do. The time of day and the weather will influence how the plan will be set in motion and what you will do first.

## The big 3 of survival

In the unfortunate situation where you do find yourself lost in the bush, follow the big three of survival: shelter, signal and fire.

**1. Shelter:** Shelter is essential to protect you from the elements. Always mark your shelter using blaze orange flagging tape, a blaze orange vest or some article of clothing that is brightly coloured. Rescuers will see the colour and investigate.

**2. Signal:** A distress call can be any series of three signals: three blasts of a plastic whistle, flashes with a reflective device such as a mirror or from a torch, or smoke from a fire. When signalling, it is important to stay where you are so rescuers can find you.

**3. Fire:** Fire can be used to boil and purify water, to keep you warm and calm, or to signal for help. For signalling with fire, add green plant material or wet timber to your flame – this will produce a lot of smoke.



## Other survival needs

### Water

If you must spend a night away from your designated camp, you may need to find extra drinking water. Almost every State forest has a water source, and these will be clearly marked on your hunting maps.

Most waterbodies carry some type of contamination, either from bacteria or runoff from livestock or agricultural crops. That is why it is important to ensure the water you drink is purified first.

Drinking water that is contaminated with bacteria can make you very sick, adding more complexity to your survival.

Water can be purified with:

- purification tablets
- portable water purifiers
- ultraviolet purifiers
- boiling.

Boiling is the safest method. Bring the water to a fast boil, let it cool before you drink it and then immediately start boiling more.

### Food

Packing some high-energy power bars or trail mix in your pack for emergency situations is a good idea. If you have harvested game be sure to cook it thoroughly. Do not eat plants or berries from the bush unless you can identify the plants as being safe for human consumption.



### First-aid basics

The majority of hunters will, at one time or another, get scratched or cut from thorns or fences and may injure themselves while using a knife. Most of the time these injuries are not life-threatening and can be treated at camp or in the field



### First aid: treating minor cuts and abrasions

Follow these three steps when treating minor cuts and abrasions.

1. Clean wound with soap and fresh water.
2. Apply antibacterial cream.
3. Apply a sterile dressing.



### First aid: insect bites and stings

If you know that you are allergic to certain insect

bites or stings, be sure to bring along any medicine you require, such as antihistamines or an EpiPen®.

For common stings and bites, relieve the discomfort by applying something cool, such as a wrapped cold pack, to affected area. This will help reduce inflammation.

Cold packs should be wrapped in a towel and placed directly on the affected area. If you are not feeling well after an insect sting or bite, seek medical help as soon as possible.

EpiPen is a registered trademark of Mylan Inc.



## First aid: snakebites

All snakebites must be treated as potentially life-threatening. You should call 000 if you have phone reception, or immediately activate your PLB if you have one. It is best to identify the type of snake that has bitten you, however, that can be difficult sometimes. If you are bitten by any type of snake, you should apply the same first-aid treatment until a medical professional can assess your condition.

Seek medical help as quickly as possible and apply the following treatment to any snakebite.

- Try and keep the victim calm, and reassure them that help is on the way. If you are alone, try to remain calm, and slow down your breathing and heart rate. Movement and panic may allow the venom to travel faster through the body.
- Apply a broad-pressure bandage to the bite site as soon as possible.
  1. Wrap a bandage from below the bite site, then upwards and over.
  2. Extend it as high as possible (e.g. all the way to the groin).
  3. Be careful not to cut off circulation to the fingers or toes.
  4. Keep the limb still (e.g. don't remove trousers).
  5. Use the same tightness as for a sprained ankle.
  6. Use a shirt or other clothing if you have no bandages.
  7. Mark the area of the bite on the bandage.

- Follow by applying a heavy bandage to immobilise the entire limb.
- Splint either side of the bite to help keep the limb from moving.
- Keep the person completely still and continue to reassure them.



## First aid: heat exhaustion

Heat exhaustion occurs when the body is unable to cool itself down. A person experiencing heat exhaustion will exhibit an increased body temperature, faintness, rapid heartbeat, a pale or grayish appearance, cold and clammy skin as well as nausea.

You can do any or all of the following to help the person experiencing heat exhaustion:

- move the person to a shady or an air-conditioned location
- have the person lie down, and elevate their feet slightly
- ensure the person drink fluids slowly
- loosen or remove the person's clothing
- use a fan to help cool the person down
- seek medical help.

## UNIT 8: BEING A SAFE HUNTER



### Introduction and learning objectives

A safe hunter is always cautious about any activity that may result in an accident or injury. Safe hunters plan ahead and analyse each situation to eliminate any immediate danger or the risk of any danger.

The unit objectives are:

- understand and practice muzzle awareness
- handle hunting equipment safely
- identify your target and know when it is safe to shoot
- harvest and handle game meat safely.

This unit discusses safety skills for handling a firearm and other hunting equipment in the field.

### Muzzle awareness — firearms and muzzleloaders



The safe direction of your muzzle will change depending on your circumstances. Generally, a safe direction is one where, in the event of an unintended discharge or fall, no harm or damage would result.

In a rocky terrain in the field, downwards may sometimes be unsafe. If there is an unintended discharge, ricocheting fragments of bullets or rock can cause injury to the shooter or bystanders.

In unpopulated areas, pointing a firearm upwards is generally fairly safe, although falling projectiles do have the potential to cause harm.

### Safe backstops and zones of fire

While hunting, you may find yourself in close proximity to other hunters and other forest users. When this occurs, you must always be aware of your zone of fire and ensure you have a safe backstop before you take a shot.

- A safe zone of fire is the area in which you may safely fire when your hunting partners are standing to your left or to your right.
- A safe backstop is an area in which your arrow or projectile will land without causing

any injury or damage. These are particularly important on public land where other forest users may be in your vicinity.

- A safe backstop is generally a riverbank, a dirt mound or a hill. Hunters must always shoot at a downward angle and know exactly where their bullet or arrow will land.

To identify your zones of fire, outstretch your arms in front of you at a 45 degree angle. The area you can see between your arms is your safe zone of fire.



**It is important never to swing your firearm outside this zone of fire.**

## Eye and ear protection

All shooting ranges in NSW require shooters to wear eye and ear protection while on the firing line. NSW DPI recommends this level of protection for hunters and recreational shooters in the field as well.

Shooting glasses will protect your eyes from hot gases and burnt powder that may cause injury in the event of an ammunition malfunction.

Hearing loss is permanent yet preventable; almost all firearms discharge is at a noise level that is damaging to your hearing; therefore, hearing protection is recommended.



## Handle your archery equipment safely

Archery and bowhunting safety rules cover all aspects of using archery equipment including storing, handling and shooting.

At times, the same rules and regulations that apply to firearms also apply to bows and arrows. Always check local regulations before bowhunting (covered in R-Licence Category 2: Hunting with bows, in Section 2 of this course). Follow these archery safety rules:

- always point the bow and arrow in a safe direction
- only place an arrow on the string (nock an arrow) only when it is safe to shoot
- be sure of your target, and what is in front of it, immediately behind it and beyond it
- never shoot over a ridge
- only shoot when you have a safe range or shooting area and a safe backstop
- do not shoot an arrow straight up into the air
- wear an armguard and finger protection while shooting bows and arrows
- handle arrows carefully
- immediately repair defects in equipment



- store your bows in bow cases — preferably hard cases — and store recurves and longbows unstrung
- store arrows in quivers.



### Handle your knives safely

Knives are an essential item that you should always carry in your hunting pack. After centuries of use, they have become a daily necessity for hunters in the bush and around camp.

Most knives are quite versatile and can be used to perform a number of tasks. Hunting knives are generally built for a specific purpose, which is to prepare hunted animals to be used as food. Most hunters will carry multiple knives that are used during the hunt for skinning, cutting meat or boning out large muscles.

A sharp knife is a safe knife. Using a blunt knife requires a stronger grip and more force to make the cut, rather than allowing the sharp blade to do the work. The extra force you need for a blunt knife can easily result in the knife slipping away from you.

Pig doggers require a specialised knife that is used to quickly and humanely dispatch pigs that have been bailed by their dogs.

Although knives can vary so much in design and function, they all present similar safety concerns that hunters need to be aware of.

Here are the top knife handling safety tips for hunters:

- always handle your knife with care
- use a razor sharp knife
- always use the right knife for the job
- cut away from your body, never towards it
- if you drop your knife, let it fall; never attempt to catch it
- never run with a knife in your hands; it must always be secured in a sheath when not in use
- make sure the lock on a folding knife is working properly
- only use a knife in a well-lit area so you can see what you are doing.



## Drugs and alcohol



In Unit 2 -Hunting laws in NSW, we discussed firearms laws. Remember, it is illegal to handle firearms if you have any alcohol or drugs in your system. This is also a good practice

for bowhunters when handling sharp broadheads and pig dog hunters when handling knives. Even after one drink, a hunter's ability will become impaired, making it extremely dangerous to handle a firearm, bow or knife. This can be the same with some prescription medications, which will generally be identified with a warning label.

A person may not feel intoxicated, but the alcohol from just one drink is enough to cloud simple motor skills, such as obtaining a clear sight picture and identifying your target beyond all doubt.

## Crossing a fence on your own



Before crossing any obstacles, a safe hunter will always make sure that their firearm is unloaded, their bow is safe or their knife is secured. Most accidents occur when a hunter forgets to follow the basic safety rules.

When crossing fences or other obstacles alone, follow these steps:

1. Check that your firearm is unloaded. Always keep the action open.
2. Carefully place the firearm on the other side of the fence or obstacle to be crossed, with the muzzle pointed in a safe direction. (The muzzle should be covered to avoid any debris from getting in.)
3. Cross the fence away from the muzzle. Retrieve your firearm and check the muzzle and action for any obstructions.
4. Once the firearm is safe, continue your hunt.

---

Hunter's tip – If you are hunting with a bow, make sure the arrows are secured in their quiver. Place the bow under the fence and cross safely.

Make sure your knife is folded or in its sheath when crossing obstacles such as fences or waterways.

---

## Crossing a fence with another person – firearms and muzzleloaders



When crossing obstacles with others, follow these steps:

1. Check that firearms are unloaded.
2. Pass your unloaded firearm to your partner,



with the action open and clearly visible (or vice versa).

3. As your partner holds both the firearms, cross the fence, away from the muzzles.
4. Your partner then hands both the unloaded firearms to you across the fence. (Make sure you both keep the muzzles pointed in a safe direction.) You then verbally confirm you have received the firearms.
5. Let your hunting partner now cross the fence, away from the muzzle direction.
6. Return your partner's firearm back to them, checking that the action is empty.
7. Reload and continue the hunt.

---

Hunter's tip—If you are hunting with a bow, make sure your arrows are secured in their quiver. Pass your bow to your partner and cross the fence. Once you have crossed, both bows are handed to you before your partner can safely cross the fence.

---

## Water crossings

Water crossings can be dangerous even when you are not carrying a firearm, bow or knife. A fast-flowing waterbody can quickly throw a hunter off balance. It is always best to find a bridge or an area that will allow you to cross without getting into the water.

If there are no other options, assess the water depth and current. Never attempt to cross water:

- if you cannot see the bottom
- that is flowing faster than your walking speed.

Only cross when it's safe and always be prepared to turn back.

Follow these steps.

1. Once you get to the river or creek, check that your firearm is unloaded, your bow is safe or your knife is in its sheath. Always keep the action of your firearm open.
2. Place the firearm in the shoulder carry position with the sling crossing your chest.
  - If you are hunting with a bow, secure it to your backpack. Both your hands will be free to help you keep your balance.
  - Knives must be in their sheath and attached to your belt or in your backpack.
3. If you are with another hunter, link arms before you enter the water and cross as one.
4. Begin to make the crossing very slowly, and continue checking for any hazards.
5. Once you have made it across, remove the firearm from your shoulder, and ensure it is safe. Check that no water has entered the barrel or chamber.
  - If you have a bow, make sure it is completely dry.
6. Continue your hunt.





## Identify your target and what's beyond — firearms and bows



In the excitement of a hunting trip, it can be tempting to shoot at any movement. However, you must always be 100 per cent sure of your target and what's beyond it before you shoot your firearm or bow. If you see a movement, colour or shape or hear a sound, assume it is human until you prove otherwise.

Before taking a shot, you must positively identify your target by asking the following questions.

1. What kind of animal is it?
2. Is it a male or female?
3. Does it have antlers or horns?
4. What colour is it?

If you are able to answer all of these questions, you have positively identified your target.

Answering these questions will also eliminate any risk of shooting at another hunter who may be carrying out an animal they have just harvested.

If you're hunting with dogs, make sure they have been trained to only hunt your target animal.

## Knowing when to shoot



Once you have positively identified your target, you should consider if the animal presents a safe and ethical shot. The following scenario is a typical example of when you should stop and think before you shoulder your rifle.

You've been hunting all day and haven't seen a single animal. It's getting late, and you are thinking about calling it a day when you suddenly see a billy in the distance. It is outside of your comfortable shooting range, but you think you might be able to get a clear shot. Should you shoot?

All hunters must ask themselves that question every time they are about to take a shot — 'Should I shoot?' The split-second decision to not take a shot in the wrong conditions is the mark of a responsible and safe hunter. When asking yourself whether to shoot or not, you need to consider many factors.

- Is the animal within your effective range?
- Is the animal within your safe zone of fire?
- Are you sure there is nothing and no one in front of and beyond the target?
- Do you have a clear, unobstructed view of the aiming point?

- Is this an ethical shot?
- Is the animal aware of your presence? If so, does it look like it is about to run?
- Will the shot be taken during legal hunting hours?

## Approaching a downed animal

Approaching a downed animal can be an exciting time. You may be full of adrenaline. You may even feel saddened by or remorseful about the events that just took place.



Always practice the safe handling of firearms and bows when looking for your animal, as you may be required to deliver a finishing shot.

Approach the animal from its back (hindquarters). This will keep your body away from its legs, hooves, antlers or horns if the animal begins to thrash about or tries to run off.

Make sure that the animal is dead and not merely injured or incapacitated by:

1. Observing the chest area for any signs of breathing or muscle contractions.
2. Ensuring there is no activity in the animal's eyes, such as blinking or movement (the eyes should look wide and glazed over).
3. Ensuring there is no movement of the animal's ear, such as twitching.

4. Touching the eye gently with a long stick (there should be no reaction when the point of the stick touches the pupil).

Once you are sure the animal is dead, unload your firearm, ensuring the muzzle is pointed in a safe direction, or make your bow safe before handling or field dressing your animal.

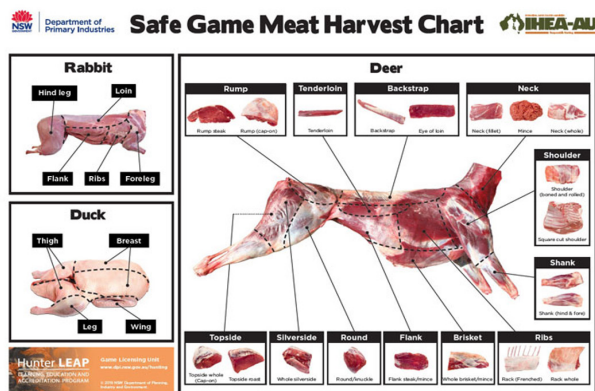

## Safe game meat handling

Skinning and gutting a hunted game animal (field dressing) is a necessary step in preserving meat from animals harvested in the wild.

Field dressing is the process of bleeding and gutting a hunted game animal. It is a necessary step in preserving meat from animals harvested in the wild. You must field dress the animal as soon as possible after your successful shot to ensure rapid cooling of the carcass and to prevent bacteria from spoiling the meat.

There are many methods to field dress game animals. This topic discuss the most user-friendly and widely accepted method in Australia.

Ideally, the carcass and deep muscle tissue must be cooled to a temperature of 7 degrees Celsius or less within 24 hours of harvest in order to minimise bacterial growth.

If the animal was killed with a humane ethical shot to the heart/lung region, there will be no need to bleed the animal. The massive damage caused to the heart, veins and surrounding arteries will have resulted in adequate bleeding.

Animals that have a damaged paunch must be dressed immediately. Any parts of the carcass that comes into contact with digesta or gut contents should not be taken for human consumption.

### **Skinning**

Skin the carcass as soon as the animal is killed. This is easily done by suspending the animal off the ground using a hunter's gambrel and hoist. If the animal is too heavy to lift, or the location doesn't allow for it, begin skinning the carcass on the ground.

The skin is a natural insulator against sudden temperature change and slows down the cooling process. Removing the skin while the carcass is still warm improves cooling of the carcass.

### **Field dressing**

Once the carcass has been skinned, you will need to remove the internal organs. Look for a clean grassy area to work so vegetation does not stick to the carcass. Make sure the animal is lying on its back or suspended off the ground.

After the internal organs have been removed, the cavity may have filled up with blood and other fluids.

If the animal is on the ground, roll the animal onto its stomach and spread all four legs apart to allow fluids to drain out.

### **Trimming**

Any meat that has been in contact with faeces, stomach contents or other questionable matter should be trimmed and discarded.

It is also important to cut away any areas affected by shot trauma. The bullet wound may also have fragments of lead or copper. Areas showing obvious bruising and contamination should also be trimmed and discarded.

Once you have field dressed the animal, you will need to remove it from the forest and prepare it for butchering.

### **Taking meat out of the bush**

Small animals can be easily carried out of the bush, even if you're hunting alone.

If you have a large, heavy animal such as a sambar deer or red deer, you may need to quarter the animal to remove it from the field.

Quarters refer to the large initial cuts of meat. These are:

1. Backstraps.
2. Tenderloins.
3. Shoulders.
4. Hind legs.

When quartering an animal, the remains of the carcass should be disposed of thoughtfully and out of view of other field users.

To keep the meat clean and dry, you should always cover the meat with a clean linen cloth or place it in a game bag.

---

Hunter's tip – DPI Hunting offers a short course on Safe Game Meat Harvest Program for hunters.



## UNIT 9: HUNTING TECHNIQUES



### Introduction and learning objectives

Not every hunting technique will be effective in all situations. You will need to adapt to your surroundings and the particular game animals that you are hunting.

Some techniques are more suited for hunting alone, while others are used when hunting in a group. Other hunters may even want to hunt using dogs to locate, point or flush small game animals or to locate and hold wild pigs. Game bird hunters will use highly trained gun dogs to retrieve downed birds from rice fields, waterways and grasslands. When used effectively, some game and predator species respond well to callers and decoys.

In this unit, you will explore various hunting techniques that can be applied to different hunting situations on both private and public lands.

The unit objectives are:

- understand the most common hunting techniques
- identify the most appropriate hunting technique for your situation
- apply the safety considerations to each technique
- use callers and decoys effectively.

### Still hunting

Popular hunting techniques for hunting game animals are: hunting from a blind, spot and stalk, still hunting and driven hunts.

**Level of difficulty:** Advanced

**Effectiveness:** Very successful when executed correctly

**Terrain:** Ideal for hunting in thick-timbered areas where visibility is limited.

Still hunting is not the easiest way to hunt and requires a special kind of hunter. To be successful, you need to be able to move through the forest very, very slowly while you scan the timber with your eyes to locate the game before it sees you.

This varies from traditional stalking, which requires you either follow sign or first have knowledge of where the animals may be located. Here are the steps to follow when still hunting.

1. **Choose the right firearm.** This is a critical step that hunters often overlook. For still hunting, choose a lightweight rifle capable of killing your chosen game animal at close range. Because you will be moving very slowly, the weight of a heavy gun can quickly tire you. Your visibility will be hampered by the dense forest, so consider using open sights or a low-powered scope that gives you a good field of view.
2. **Choose the best time.** Timing is crucial in this type of hunting. It is best to still hunt when the animal is moving, feeding or browsing. Try early mornings and late afternoons when the animal has begun to travel towards its feeding grounds.



3. **Keep the wind in your face.** Most animals have a sense of smell up to 40 times stronger than that of a human. Even though they cannot accurately locate the source of the scent, an animal's sense of smell alerts it to the presence of danger.
4. **Pick your path.** Look down, and pick out an easy path forward. Your path needs to conceal your movements as well as offer a quiet approach.
5. **Keep your approach quiet.** Unnatural sounds and noises will alarm any wild animal. Remove or fasten items to stop them from making unnatural noises. If you do snap a twig or snag a branch, remain motionless for a few minutes. Keep looking into the woods for animals that might have been disturbed.
6. **Be patient and vigilant.** Take a few steps forward while looking into the forest, not down at the ground. Walk three to five metres, then stop and look into the timber for any sign of an animal. Try and stay out of sight by using ground cover, trees and land contours. Stick to the shadows and do whatever you can to conceal your forward movements. Each step you take will uncover a new section of the forest. The trick is to look more than you walk.

7. **Mimic the sound of the animals.** All animals make sounds when they are feeding and moving. The noises you make should sound natural. Game animals are very inquisitive, and some sounds can actually attract their interest.

## Spot and stalk

**Level of difficulty:** Moderate

**Effectiveness:** Very successful

**Terrain:** A high vantage point to sit and spot the animal

A popular method in Australia, you don't need an intimate knowledge of an animal's movements, their habits or the terrain they live in to use the spot-and-stalk technique. The animals will be unaware of your presence and will move about and feed unalarmed.

You will need a quality pair of binoculars, like a pair of 8x42 binoculars at a minimum, and possibly a spotting scope to allow you to judge the animal in fine detail from a distance. Here are the steps to follow when spotting and stalking.

1. **Choose your vantage point.** Choose somewhere high with a good view of the terrain.
2. **Pick the time of day.** In the early mornings, look into sunny areas and north-facing slopes where the animals will be warming themselves. In the afternoons, concentrate your efforts on feed areas or game trails leading to these spots.
3. **Judge the game.** Before you begin stalking, fully assess all of the animals, and choose the ones you wish to take.

4. **Stalk your chosen animal.** Go very slowly, planning each step before you take it. Animals have highly developed senses of sight, smell and hearing, so you will need to overcome these senses in order to get within shooting range.
5. **Always keep the wind in your face.** Your scent will alert the animals to your approach long before you will see them.



## Hunting from a blind

**Level of difficulty:** Easy

**Effectiveness:** Very successful for a patient rifle hunter or bowhunter

**Terrain:** Open, barren grounds or flat landscapes that provide no cover for still hunting or stalking

A hunting blind is a cover device you can use to reduce the chance of detection. In open landscapes, the game will see you approaching well before you see them. Hence, the use of a blind could very well give you the advantage.

Here are the steps to follow when hunting from a blind.

1. **Choose a blind.** Your blind could be as simple as some fallen timber or a small bush to conceal

your presence. You can make a blind from almost any natural resource or buy a pop-up blind that is very lightweight and easy to set up. Most good hunting retailers offer a tent-like blind available in many different camouflage patterns.

2. **Choose your site.** Choosing your site is the most important part of setting up your blind. Make sure that the blind looks as natural as possible and offers a clear view of the animals. It must also be concealed so it does not interrupt the natural landscape. Always consider the wind direction, as the unnatural scent of the blind and your scent can spook the animals.



3. **Set up the blind.** Make sure the blind looks as natural as possible. You are in the animal's home, and it is sure to notice a new pop-up blind sitting out in the open. Always make sure the wind is in your face. Human scent wafting into your hunting area will surely spook every animal within nose shot. If you can, set up the blind before you plan to hunt the area. This will give the animals some time to get used to the blind's presence.



4. **Clear a shooting lane.** Using a blind means you don't have the flexibility of movement to improve the sighting of an animal. Take some time to clear any limbs and branches that could get in the way of a successful shot.
5. **Choose the best time.** Timing is crucial. Try and get into your blind before daylight. Alternatively, try early in the afternoon before the animals begin to feed. It is important to avoid bumping into an animal on your way in. Walk to the blind downwind, keep your movements concealed and avoid using game trails. Animals will pick up your scent if you're using the same trails as they are.

## Calling foxes and cats

Many hunters may own a fox call or whistle. The European red fox and the feral cat are introduced predators that cause significant damage to Australia's vulnerable and unique native wildlife species. Feral cats and foxes are one of the primary causes of the decline and extinction of many Australian native species. They are carnivores and opportunistic hunters that will readily respond to the distress calls of prey animals such as native mice, small marsupials and young livestock. These calls can also attract other predator species such as wild dogs and even wild pigs.

## Types of callers

### Mouth whistles

The most common callers are the button and the Tenterfield mouth whistles.

These whistles are low cost, very effective and

a user-friendly tool. The design produces a mid-range, high pitched sound that replicates the distress call of a rabbit. Volume is easily controlled by the amount of air entering the whistle. The effective range of this whistle is limited to the environment and wind conditions that you are hunting in.



### Hand-operated callers

These shaker-style calls are more difficult to use but produce a wider range of sounds and volumes. They can be operated using both hands to gain full volume that can be heard at extremely long ranges. They can also be gently shaken to produce a quiet squeak when the target is in close proximity.

### Electronic callers

They can be used to attract a variety of predators including foxes, feral cats, wild dogs and even wild pigs. Some callers are pre-loaded with standard distress and mating calls, while other designs allow you to download and store different types of calls on the device. Each call has its own purpose and can be more effective when used at the right time.

Hunter's tip – A very loud and raspy call used on a wet or windy night may attract distant foxes. Soft, quiet and squeaky calls are used to tempt your target animal if they are in close range, hunting in feed sheds or patrolling stubble fields.

### Using your caller effectively

The aim of using a caller is to imitate the distress cries of a prey animal in pain, such as a rabbit.



Follow these steps to achieve the right technique.

1. Limit any movements. Make sure you are in a suitable location with a high vantage point, good cover and with the wind in your face.
2. Begin with four to five soft, low calls in the first minute in case there is a fox close by. Loud and raspy calls will likely spook any nearby predator.
3. Next, make a series of louder calls for 30 seconds, beginning with a very loud cry and tapering off to a low whimpering sound.
4. Stop and wait for one minute before repeating. Continue this strategy for the next five to ten minutes.
5. Take a break from calling for five minutes, and closely scan the area with your binoculars.



6. If you see an animal, use soft whimpering squeaks to arouse their interest. The softer calls will make the fox rely heavily on their sense of hearing and may distract them from your presence.
7. If you haven't spotted an animal within 30 minutes, move to a new location at least 500 metres away and try again.
8. Limit the sound and volume by covering the end of the caller with your fingers to restrict the airflow.

### END OF SECTION 1: MANDATORY TRAINING



## SECTION 2, CATEGORY 1: HUNTING WITH FIREARMS



### Introduction and learning objectives

Hunters are personally responsible for the quick and humane harvest of game animals. When you are hunting with firearms, you must use the correct rifle and ammunition combination that will deliver enough energy and killing power at the distances you are confident shooting at.

In this course, we explore the many different types of firearms that can be legally used by hunters in New South Wales (NSW). We will also discuss different types of ammunition, their suitability for different hunting methods and the shooting skills needed to ensure a quick and humane kill while hunting game animals.

The category objectives are:

- be tested for a NSW restricted game hunting licence (R-Licence) to hunt with firearms (rifles, shotguns and muzzleloaders)
- understand the functions of common firearms parts

- select suitable firearm and ammunition combinations for different types of hunting
- practice the safe storage and transport requirements when you are hunting
- identify what minimum calibres, projectile weights and shot sizes are generally recommended for hunting various species
- sight-in and fine-tune a firearm for accuracy
- safely handle common firearm and ammunition malfunctions.

### Being a legal firearms user

In Unit 2 of Section 1-Hunting laws in NSW, we discussed laws relating to the possession and use of firearms. To hunt with firearms in NSW, you must hold an appropriate firearms licence, issued by your state agency, that is endorsed for the relevant firearm categories and genuine reason.



To hunt on public land in NSW with firearms, you must successfully complete Section 1 of this course, as well as this licence category. When your application for a NSW game hunting licence is approved and processed, you will then be able to book a hunt and use firearms to hunt on public land in NSW.



## KNOW YOUR FIREARMS



### How a firearm operates

A firearm propels a projectile, generally from an explosion of either propellant, gas or air.

To fully appreciate the importance of firearms safety, you must first understand how firearms work. This includes knowing the parts of a firearm, the types of ammunition, how that ammunition is fired and the various types of firearms that are suitable for hunting.

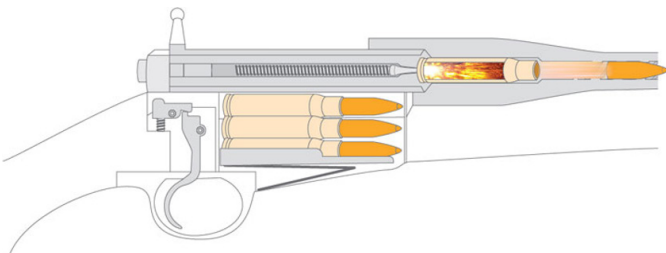

### Difference between rifles and shotguns

Both rifles and shotguns feature a long barrel and are braced against your shoulder when fired. The two differ on the type of ammunition used and the design of the barrel.

Rifles fire a single projectile (bullet) that can travel great distances. This requires great force and accuracy, so the inside of the barrel is very

thick and contains spiralling grooves and lands, known as rifling, to spin the projectile to increase accuracy as it moves toward a target. Lands are the raised portions between the grooves.

Shotguns, in contrast, can fire either a single projectile (slug) or multiple projectiles (shot). Generally, shotguns have a shorter range than a rifle; therefore, the barrel is much thinner as it doesn't have to handle as much pressure. Generally, shotgun barrels are smoothbore and contain no rifling.

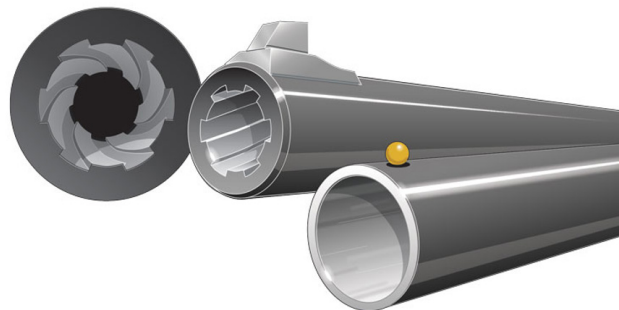

### Rifle parts

Over the last century, modern firearms have changed very little. They are still made up of the same three basic elements: action, stock and barrel.



#### 1. Action

The action is the heart of the firearm — the moving parts that load, fire and eject the shotshells or

cartridges. There are several types of actions used in modern firearms:

- bolt action
- lever action
- pump action

- break action
- self-loading action (restricted).

## 2. Stock

The stock serves as the handle of the firearm. It can be composed of one or two pieces and is made

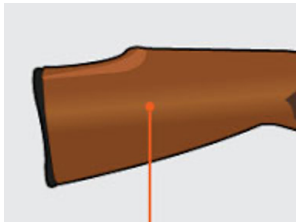

of wood or a synthetic material. It is the part of the gun which is held, or braced, against your body.

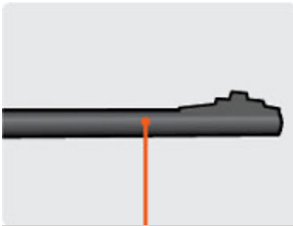

## 3. Barrel

The barrel is the metal tube that the projectile travels through.

## Glossary

### Cartridge

Ammunition used in modern rifles; a case containing primer, gunpowder and a projectile.

### Shotshell

Ammunition used in modern shotguns; a case containing primer, gunpowder, wad and a slug or a shot; can be loaded with multiple pellets or a single slug as the projectile.

## Other parts of a firearm

The numbers in the image correspond to the numbers in the list.

1. **Stock**
2. **Action**
3. **Barrel**
4. **Sight:** The sight is an alignment device to help

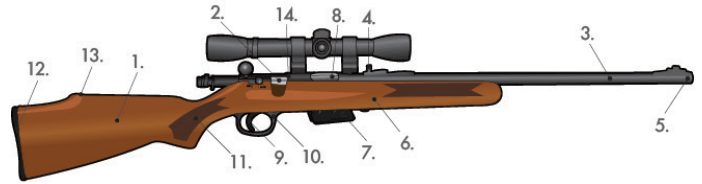

aim a firearm. In the image, the rifle uses an telescopic sight.

5. **Muzzle:** End of the barrel through which the projectile (bullet or shot) exits.
6. **Forend:** Front portion of the stock that supports the barrel in front of the receiver.
7. **Magazine:** The magazine acts as a storage device for cartridges or shotshells. The magazine can be either tubular (tube that runs underneath the barrel) or a detachable box-type (shown in the image).
8. **Chamber:** The chamber is the part inside the barrel where the ammunition is loaded and ready to be fired.
9. **Trigger:** When pulled, the trigger releases the firing pin that hits the primer on the cartridge.
10. **Trigger guard:** The trigger guard helps protect the trigger from being accidentally pulled.
11. **Grip:** The grip is the part of the stock that is held by the shooting hand when the hunter is positioned to fire.
12. **Butt:** The butt is the end of the stock that is braced against the shooter's shoulder when taking a shot.
13. **Comb:** This comb is the top most side of the stock. In some cases, the comb might be raised from the stock and is known as a cheekpiece.
14. **Breech:** The breech is the end of the barrel, opposite to the muzzle.

## Bolt action

A bolt-action firearm operates like opening and closing a door bolt.



### Loading

The bolt can be lifted and pulled back to see whether the chamber is loaded. While closing the bolt, a cartridge from the magazine is guided into the chamber, which loads the firearm. Generally, if the chamber is loaded, a cartridge is ejected when the bolt is opened and pulled rearward.

### Unloading and inspection

To unload the bolt-action firearm, point the muzzle in a safe direction, and pull the bolt back until the cartridge comes out and push the bolt forward again. Do this until no more cartridges come out of the chamber and then leave the action open.

Inspect the chamber both with your eyes and with your fingers to ensure there is no cartridge in the chamber. Say the word 'empty' when you are convinced the firearm is unloaded.

## Lever action



A lever-action firearm usually has a shorter barrel, is lighter to carry and is easier to operate for follow-up shots. A popular style of action among

rifles, it is a good choice if you are hunting in thick bush. Most lever actions have a loading gate where the cartridges are pushed into a tubular magazine.



### Loading

To load a cartridge from the magazine, grasp the lever and swing it down and away from you. Make sure that the barrel is pointed in a safe direction. Next, swing the lever up and towards you. This releases a cartridge from the magazine, chambers the cartridge and closes the action. After you load, engage the safety if your lever action has one; otherwise, place the hammer at half-cock position. After firing the lever action, swing the lever down and away from you to eject the cartridge.

### Unloading and inspection

To safely unload a lever action, point the muzzle in a safe direction. Swing the lever forward and back again — do this as many times as required until no more cartridges are ejected, and then leave the action open.

With your eyes and finger, inspect the chamber to ensure there is no chambered cartridge. Say the word 'empty' when you are certain the firearm is unloaded.

---

Hunter's tip—Be extremely careful when lowering the hammer to a half-cocked position.

---



## Pump action

A pump-action firearm allows a hunter to quickly eject and chamber a new round.

### Loading

It is typically loaded from the bottom into a tubular magazine. The action is opened when the forearm is pulled back to the rear of the firearm. Pushing the forearm forward moves the ammunition from the magazine into the chamber and closes the action so that the firearm is loaded and ready to be fired. On most pump-actions, a slide lever located by the trigger guard releases the action so you can inspect the chamber or unload the firearm.

### Unloading and inspection

To unload a pump action, point the muzzle in a safe direction. Pump the forearm back and forth until no more cartridges are ejected, and then leave the action open.

Inspect the chamber with your eyes and finger to ensure no ammunition is chambered. Say the word 'empty' when you are sure the firearm is unloaded.

---

Important – Pump-action and self-loading shotguns are prohibited except for limited purposes. Please consult the NSW Police Force Firearms Registry for more information.

---

## Break (or hinge) action

A break (or hinge) action firearm is available in single-and double-barrel types and more recently triple-barrel styles. Because of the limit this firearm places on shots per use, it is ideal for novice hunters. Most firearms with this type of

action feature two barrels placed either side-by-side or in an over-and-under configuration.

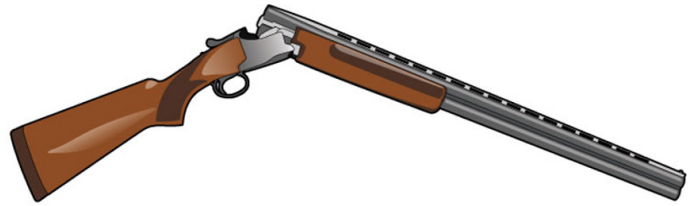

### Loading

To load, push on the action release lever, and pivot the barrels down. The chamber will then be separated from the stock and firing mechanism so ammunition can be inserted. Once you close the action and release the safety, the firearm is ready for firing.

### Unloading and inspection

After firing, press the release lever to open the action and eject the spent cartridge or shotshell. Some break-actions have automatic ejectors; others require that you manually remove the spent cartridge or shotshell.

To safely unload the break action, point the muzzle in a safe direction, and open the action. The ammunition might eject automatically, or you might have to pull it out by hand. Afterward, inspect each chamber to ensure no ammunition is chambered. Say the word 'empty' when you are sure the firearm is unloaded.

---

Important – Some break-action firearms have an exposed hammer.

---

## Air rifles

The projectile of an air rifle is propelled by means of compressed air or gas. Air rifles are the most common type of firearm people use to learn about shooting technique and safety. These firearms are relatively inexpensive to buy and operate. It is important to remember, however, that an airgun or air rifle is still capable of causing serious injury.



Modern air rifles are now being manufactured in calibres that are capable of taking game animals with ease.

## Shotgun types

Shotguns use many of the same actions that you would find in rifles:

- bolt action
- lever action
- break action
- pump action (restricted)
- self-loading (restricted).

A break-action shotgun is the most commonly used shotgun for hunting. It comes in a variety of barrel configurations; the most popular being the double-barrel shotgun.

Double barrels can either be constructed horizontally (side by side) for shooting at running game animals or vertically (over and under) for shooting at flying game animals and clay targets.

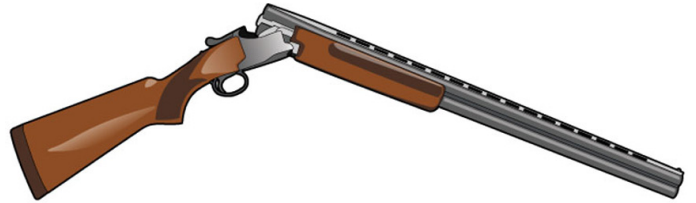

Important – Pump-action and self-loading shotguns are prohibited except for limited purposes. Please consult the NSW Police Force Firearms Registry for more information.

## Gauges

Shotguns are manufactured with different bore diameters, and each size is referred to as a gauge.

The common shotgun gauges are:

- 10 gauge
- 12 gauge
- 16 gauge
- 20 gauge
- 28 gauge
- 410 gauge.



.410 Bore Diameter	28 Gauge .550" Diameter	20 Gauge .617" Diameter	16 Gauge .670" Diameter	12 Gauge .727" Diameter	10 Gauge .780" Diameter
-----------------------	-------------------------------	-------------------------------	-------------------------------	-------------------------------	-------------------------------

### 28 Gauge

28 Lead Balls the diameter of the bore equal to 1lb



The 12 gauge is the most versatile and can be used for game hunting, game bird hunting and target shooting.

## Chokes

On most shotguns, the diameter of the barrel at the muzzle end is constricted. This is known as the choke.

The purpose of the choke is to control the pattern of shot as it leaves the barrel. Generally, the distance at which you are shooting will determine the most suitable choke.

The choke can be either built into the barrel during manufacture or supplied as an interchangeable item that is screwed in.

There are four main choke sizes that will cover most hunting and shooting applications.

- **Cylinder choke** — is the same diameter as the bore. The shot pattern will spread quickly. This choke can also be used for solid slugs.

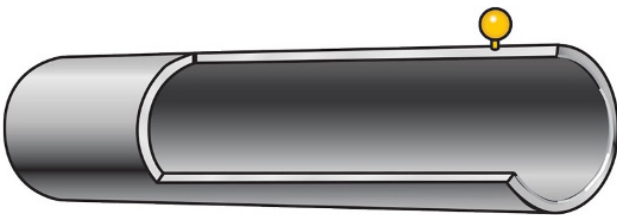

- **Improved choke** — allows the shot to spread fairly quickly. This choke is suitable for small game, such as rabbits and quail.

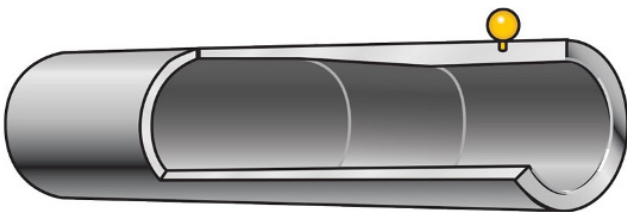

- **Modified choke** — is very useful for longer range shooting. The shot pattern is dense and holds the pellets closer together. This choke is very popular for most hunting situations.

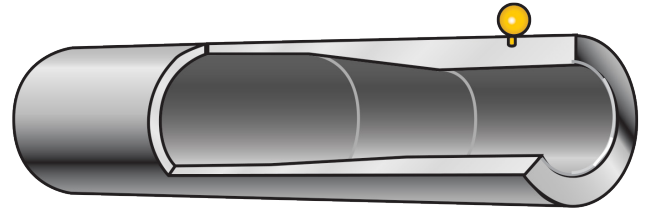

- **Full choke** — The shot pattern holds together much longer than a modified choke and concentrates most of the pellets on the centre of the target.

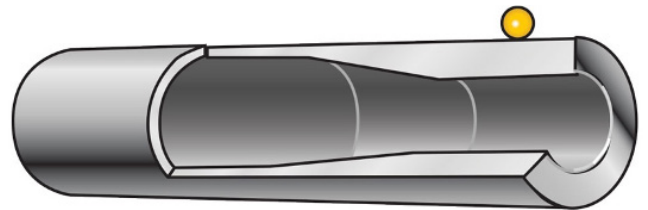

## Blackpowder firearms

Blackpowder was the first type of propellant invented over 1,000 years ago. Initially used in fireworks, blackpowder made its way into weaponry, leading to the design of handheld firearms in the 13th century. Blackpowder firearms revolutionised the way humans hunted for their food and protected themselves from predators.

These firearms (also known as muzzleloading firearms) are loaded from the muzzle end, have a trigger mechanism for firing and a stock for holding the firearm. They fire either a single lead ball or multiple smaller lead pellets.



Compared with other firearms, blackpowder firearms require considerable skill to load, since each charge is loaded at the muzzle end of the barrel. They also require substantial skill when hunting game because, with the exception of double-barrel versions, they only provide a single shot at relatively close ranges. That's why many are attracted to the challenge of muzzleloading firearms.

It is important that hunters using blackpowder firearms understand how they work and how to use them safely to maintain high ethical hunting standards and acceptable animal welfare outcomes. Used within their accurate range, blackpowder firearms are more than capable of delivering one-shot instantaneous kills. Should you choose to purchase one, be sure to go to a shooting range with someone who has experience using a muzzleloader and have them teach you how to use it properly.



## Hunting with blackpowder firearms on public land

Blackpowder ignites with an impressive blast that generates a large muzzle flash and puff of

smoke. The muzzle flash can be a fire hazard, as the embers discharged from the muzzle have the potential to ignite dried vegetation.

This means that blackpowder firearms are not permitted for use on public land during solid fuel fire bans and total fire bans. Remember to check your Written Permission, advisories and the NSW Rural Fire Service's 'Fires Near Me' app (available both on App Store and on Google Play Store) before beginning your hunt.



## Know your blackpowder firearms

There are three common types of blackpowder firearms that are used by hunters. They differ only in their action type and how the powder charged is ignited.

1. **Break-action muzzleloader.**
2. **Inline percussion muzzleloader.**
3. **Flintlock muzzleloader**

Let's take a look at the common parts of a blackpowder firearm.

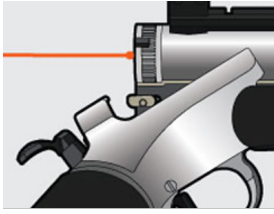

### Breech

The breech is where the primer is placed. In most of today's modern muzzleloaders, the breech

can be removed by hand for easy cleaning and to remove the load if you are not going to fire it.

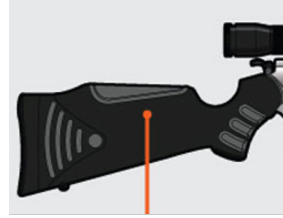

### Stock

The stock supports the action and the barrel of a firearm and also helps absorb the recoil.

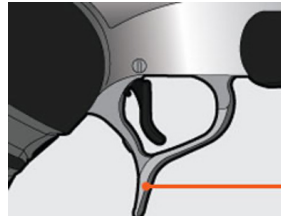

### Trigger

The trigger is depressed to begin the firing process.

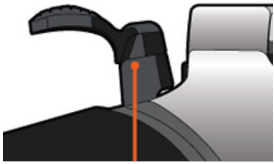

### Hammer

The hammer is used to fire the muzzleloader. It strikes the firing pin, which then

strikes the primer or priming charge, producing a spark to ignite the powder.



### Ramrod

The ramrod is used to load (seat) the projectile into the barrel. It is also used as a cleaning rod.

---

Important –If your muzzleloader has a wooden ramrod, the ramrod can shatter under pressure, causing injury. Always exercise caution when using a wooden ramrod, and avoid using one that shows any sign of damage.

---

## 1. Modern break-action muzzleloader

The modern break-action muzzleloader is very popular today. It works similar to other break-action firearms. The break-action muzzleloader is loaded in the same manner as all other muzzleloaders, but its break-action feature allows the shooter to access the breech and insert the primer much easier.

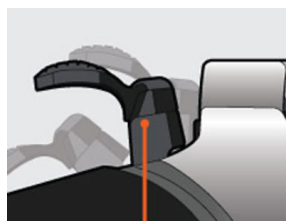

### Safety

The safety on most muzzleloaders with an exposed hammer is when it is set to half-cock. Some

muzzleloaders may also have a push button safety.

### Removable breech plug

A key feature that makes these modern muzzleloaders unique is that they have a removable breech that can be installed and removed by hand. This is very useful when cleaning your muzzleloader and if you want to remove the unused powder and projectile that was not fired.

Always refer to your muzzleloader's manual on how to properly and safely remove the breech.

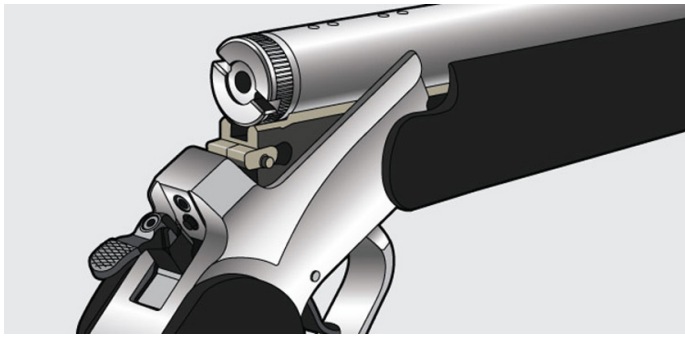

## 2. Inline percussion muzzleloader

The modern inline muzzleloader looks like most modern firearms. Some are equipped with a safety, and even a telescopic sight can be attached to certain models. Some inline muzzleloaders are also equipped with an electronic ignition, where a tiny spark is produced in the breech, and ignites the gunpowder more rapidly than a percussion cap would.

The inline and caplock muzzleloaders differ on where the nipple is attached. In an inline muzzleloader, the cap is in-line with the hammer and the barrel. The inline has the nipple attached to the barrel at the breech and accessed by a bolt or break action. Also, the inline model has a removable breech plug, to facilitate cleaning.



Apart from the basic parts listed earlier, the firing mechanism contains the following parts.

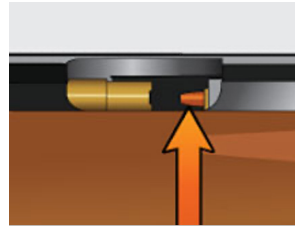

### Nipple

The nipple is a small metal tube that is tapered and screws into the breech plug. The

percussion cap is pushed onto the nipple and is held on by tension.

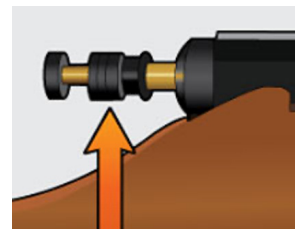

### Hammer

The hammer strikes the percussion cap, producing a spark.

## 3. Flintlock muzzleloader

The flintlock muzzleloader dates back to the 17th century and features a flintlock mechanism that produces sparks when a piece of flint strikes its steel frizzen.



The firing mechanism consists of the following parts:

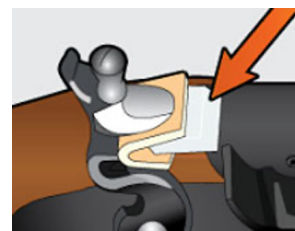

### Flint

A flint is a hard, fine-grained form of quartz stone mounted in the hammer that creates a shower of sparks when it

strikes the steel frizzen.





### Hammer

A hammer is the part of the firing mechanism that holds the flint.

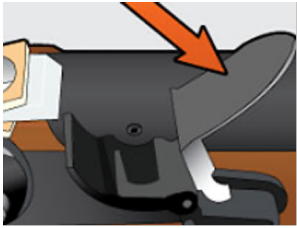

### Frizzen

A frizzen is a piece of steel that is struck by the flint to create sparks. The frizzen also covers the priming charge in the flash pan.

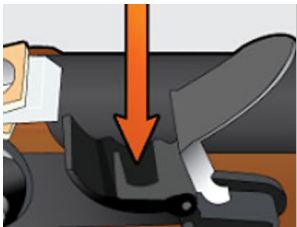

### Flash pan

A flash pan is a small groove cut in the firing mechanism to hold the priming charge.

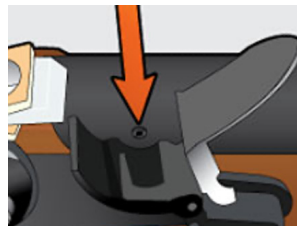

### Touch hole

A touch hole is located at the side of the barrel at the edge of the flash pan.

## Safeties for all types of firearms

Every modern firearm and most blackpowder firearms have a built-in safety feature that will prevent the firearm from firing.

While safeties can be in various styles according to the manufacturer, this topic discusses some of the most common types of safeties.



Important – The safety is a mechanical device and consequently subject to failure. While it is important to know how a safety works and how to use it properly, a safety is no substitute for the most basic rule of firearm safety. Always keep the firearm pointed in a safe direction.

## Types of safety mechanisms

### Push-button safety

Located on the trigger guard, a push-button safety blocks the trigger or the hammer when engaged. It may have a visible red band when the safety is in the off position.

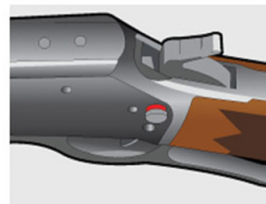

Safety Off

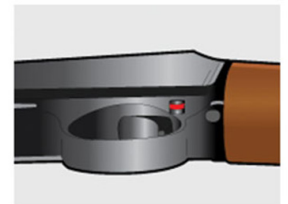

Safety Off

### Slide or tang safety

It features two positions of operation:

- in the on position (i.e. a green-coloured dot or the letter 'S' may be visible), it blocks the firing mechanism of a rifle or shotgun
- in the off position (i.e. a red-coloured dot or the letter 'F' may be visible), it enables firing of a cartridge or shotshell.

A tang safety, featured on some models of shotguns, is engaged when the letter 'S' is visible on top and in the back of the receiver.

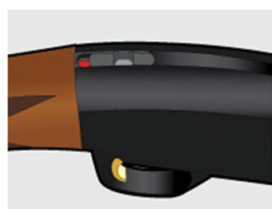

Safety Off

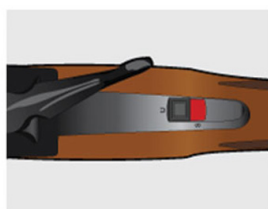

Safety Off

### Lever or pivot safety

Located either on the bolt or just behind the bolt handle on the frame of the receiver, it blocks the firing pin when engaged. On some firearms, the lever safety located on the bolt will have three positions:

- the back position (i.e. towards the shooter) does not allow the bolt to be opened, and the firearm will not fire
- in the middle position, the bolt can be cycled, but the firearm cannot be fired
- in the forward position, the safety is off, and the firearm can be fired.

Other safeties have only two positions: on and off.



Safety Off

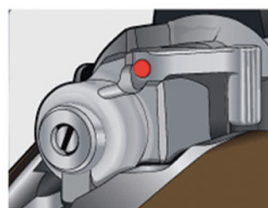

Safety Off

### Hammer or half-cock safety

This type of safety is not as common as others. It is typically found among lever-action and break-action firearms or antique and replica firearms. In the half-cock position, the hammer does not rest

on the firing pin, and the trigger is locked. When the hammer is pulled all the way back into the cocked position, the firearm can be fired.

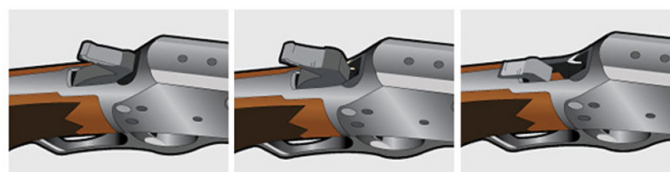

Step 1. Closed

Step 2. Half Cock

Step 3. Full Cock

Important – The trigger must be pulled to move the hammer from 'full' to 'half-cock' position. Make sure that you have full control of the hammer before you touch the trigger and that it does not slip from your grasp as you move it into the half-cocked position. Always keep the muzzle pointed in a safe direction.

## Types of sights

Most rifles and shotguns feature a sight, which is a device that helps a hunter take aim. All sights will need to be adjusted correctly to consistently hit the target with an acceptable degree of accuracy. There are three categories of common sights.

### 1. Telescopic sight



Consisting of a main tube with lenses to magnify distant objects, it has vertical and horizontal lines that intersect to form crosshairs (used for lining up the centre of a target).

This sight is mounted on top of the barrel or action of a firearm.

The telescopic sight is available in fixed powers, and some models have an adjustable ring that you can use to select different powers of

magnification. Since it is easy to use, it is a good choice for novice hunters.

## 2. Aperture or peep sight



Usually mounted at the rear part of the rifle action, an aperture sight has a base and a raised ring. It is adjustable for vertical and horizontal movement. Aim at a target by mounting the

firearm and peering through the peephole of the rear sight, centring the front sight within the circle of the rear peep sight. The front sight can be a metal post with a ball on top or just a metal post. Aperture or peep sights are common on target rifles.

## 3. Open sight



Featuring a notch or cut at the rear and a single post at the front or muzzle end of the barrel, open sights are common features on rifles and pistols. Many of the newer open sights have the

front and rear sight made of fibre optic material of contrasting colours that gather light and are easier to see in low light.

## Sight picture

Sight picture is the rear sight, front sight and the target all in perfect alignment.



Telescopic Sight



Aperture or Peep Sight

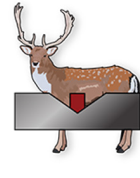

Open Sight

## Sight alignment of a rifle

The flight of a bullet is not a straight line to the target. Gravity, air resistance and energy loss all influence flight. A hunter must always take that into consideration when sighting-in. A bullet sighted-in to hit a bull's eye at 100 metres might be 1 inch or 2.5 centimetres above the bull's eye at 50 metres. You need to know what type of game will be hunted, and only sight-in with the ammunition that you will use while hunting.

The key to sighting-in a firearm is to reduce all movement between you shoulder and the rifle. You will need a good solid bench to sit at, and a solid rest for the firearm – sandbags, carpeted wooden blocks or a tripod all work well. It is important that you exercise breath control at the moment the trigger is pulled, because the rise and fall of your chest when breathing can influence a bullet's trajectory.

Trajectory is the arc of the bullet from the firearm's muzzle to final impact. A bullet will rise and fall, crossing the line of sight twice over a certain distance. Knowing the flight path of your bullet will allow you to adjust your point of aim to the bullet's point blank range.

Mid-range trajectory is the bullet's highest point above the line of sight. This will usually occur halfway between target zero and the muzzle.



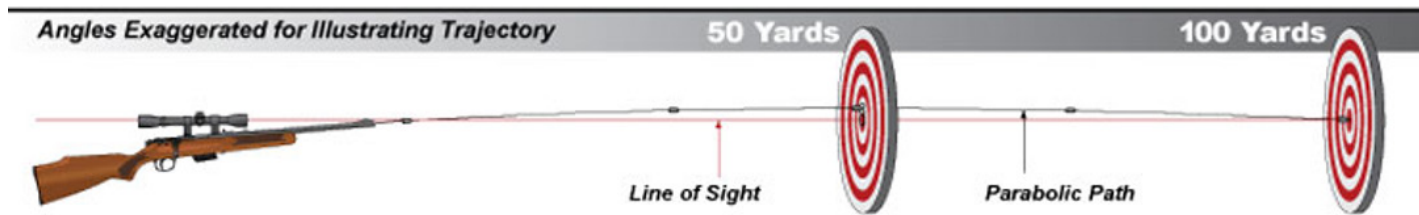

### Point blank range

Point blank range relates to the flight path of the bullet hitting the vitals of an animal without compensating for distance. It is always described as a distance.

The point blank range allows you to aim at the centre of the vital area of your targeted big game animal without your bullet's trajectory rising or falling more than 3 inches (75 millimetres) during its flight to the target. This avoids the need for you to compensate for the extra distance when hunting larger game animals.

---

Hunter's tip – To convert to metres from yards, use this conversion: 100 metres = 110 yards

---

### Sighting-in a rifle

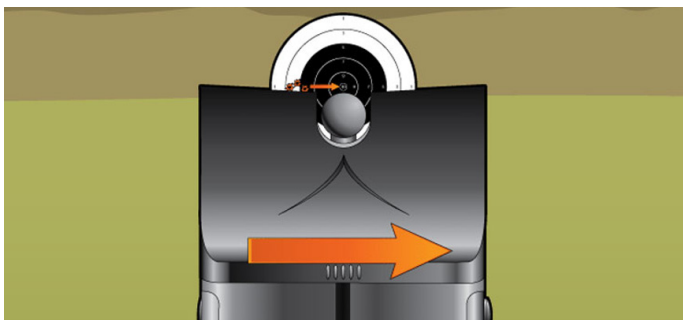

#### Open sight adjustment

After firing a number of shots, check to see where the bullets are grouping.

If using an open sight, adjust the sights if the shots are not in the centre of the target. With an open sight, move the rear sight in the direction you want the shots to move on the target.

#### Telescopic sight adjustment

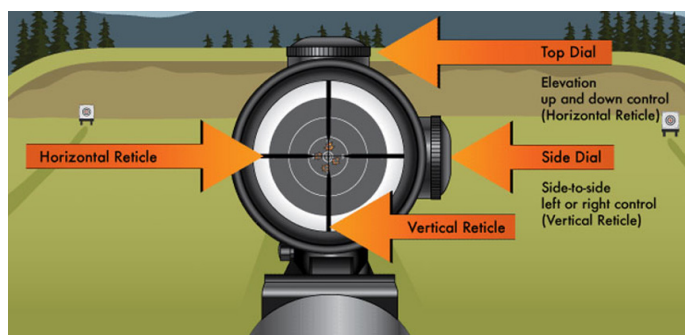

When using a firearm with a telescopic sight, use the dials on the top and side of the scope to move the crosshairs to the aiming point.

The elevation (up and down) is usually the top dial and affects the bullet's point of impact vertically. The windage is usually on the right side of the scope and affects the bullet's point of impact horizontally (left and right).

If the bullet needs to go towards the top of the target, adjust the elevation dial in the same direction (as indicated on the dial).

If the bullet needs to go towards the right side of the target, adjust the windage dial in the same direction (as indicated on the dial).

---

Important – Remember it is a general written permission condition that sighting-in or target shooting is not permitted on public land.

---

## Targeting and patterning a shotgun

There are differences in targeting shotguns and rifles. While shotguns are pointed at a target, rifles are aimed. The trigger pull on a shotgun is quick – often described as ‘slapping’ the trigger. It is important to know your dominant eye when using a shotgun, because you will have both eyes open when taking a shot.

Patterning a shotgun is a very important element in finding the effectiveness of your shotgun, ammunition and choke combination. Patterning a shotgun will reveal:

- point of impact
- pattern density
- pattern percentage.

You will need to pattern your shotgun at an approved range with the type of ammunition you will be using during your hunt. You will also need to know the number of pellets per shot size of your cartridge. This can be found on the cartridge manufacturer’s website.



## Steps for patterning a shotgun

To pattern your shotgun, you will need:

- a 35 metre target
- 1 metre x 1 metre butchers paper and a supporting frame
- a black marker.

Follow these steps to pattern your shotgun:

1. Attach the paper target to a frame at 35 metres.
2. Mark a 5 centimetre black circle at the centre of the paper target.
3. Fire one shot at the centre of the target.
4. Draw a 75 centimetre circle around the greatest density of holes in the target.
5. Count how many pellet holes are within the 75 centimetre circle. You can mark each hole so that you don’t lose count.
6. Divide the number of holes counted in the 75 centimetre circle by the number of pellets in an unfired cartridge.
7. Repeat this process a minimum of three times and calculate your average.

The percentage of pellets that hit inside the 75 centimetre circle will vary depending upon the choke you are using in your shotgun. The chart below shows the general acceptable pattern percentages.

Full choke – 70% or higher

Modified – 55%–60%

Improved cylinder – 45%

Cylinder – 35%–40%

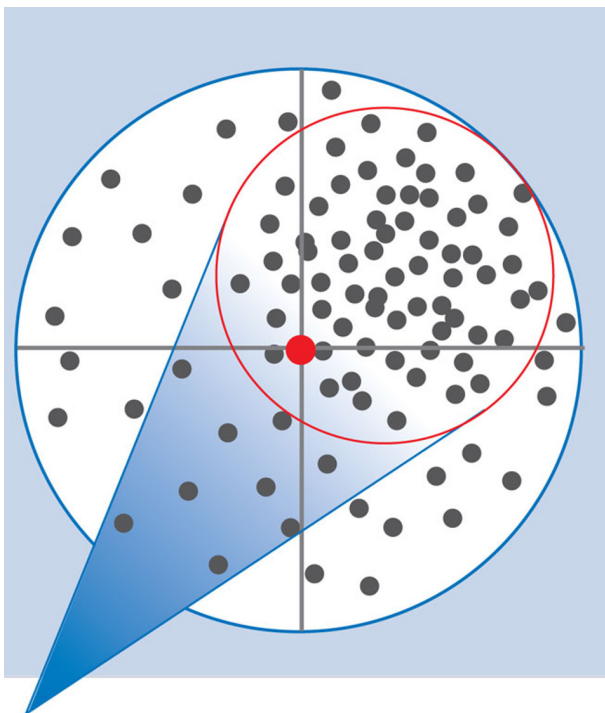

## Accuracy

Hunters with a good amount of knowledge, skill and experience should be able to consistently hit a target accurately from a variety of field positions. When hunting, dependable accuracy is crucial to ensure the game animal you are targeting is killed quickly and humanely.

Once the rifle has been correctly sighted in, the main contributing factor to dependable accuracy is your skill level. However, sometimes things can go wrong and your rifle won't shoot with acceptable accuracy. Talk to a qualified gunsmith about how they can tune your rifle to maximise its accuracy.

## Shotgun sights

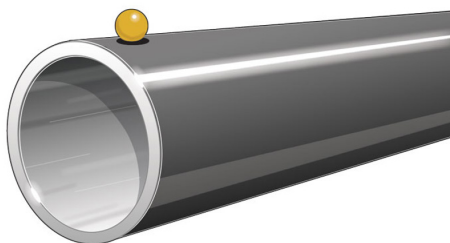

Shotguns do not usually have rear sights. Most have a round bead sight at the muzzle end and a ventilated rib on top of the barrel. When pointing a shotgun at a target, the rib and front bead should be aligned so that you are looking straight down the barrel, to properly hit the target. If the bead appears to be higher or lower than the rib, then you are not looking straight down the barrel, and the shot will not hit the intended target.

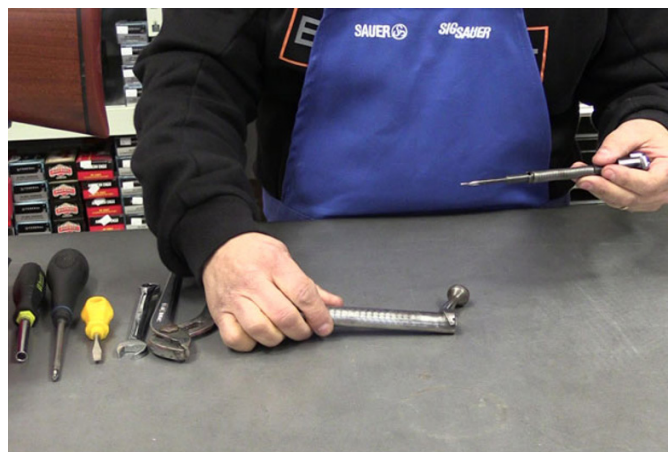

## Trigger

A heavy trigger or a trigger with creep can significantly affect your rifle's accuracy. To pull and break the trigger to fire a round, you may have to use excessive pressure. This can sometimes result in you jerking the rifle off the target.

A heavy trigger can also cause you to develop a flinch. Anticipating when the trigger is going to break is the most common cause of a flinch.





The recommended weight of trigger pull for a hunting rifle is about 1.4 kilograms or 3 pounds. The trigger should break clean and crisp without any creep or backlash.

Only have a qualified gunsmith adjust your trigger, and never attempt to lighten a trigger yourself. It is dangerous to reduce the trigger weight to less than 1.4 kilograms, and any errors could result in an inoperable rifle.

## Action bedding and free-floating rifle barrels

The action is the part of the rifle that attaches the barrel to the stock and, if properly mounted or bedded, will minimise barrel movement during the recoil of firing.



Bedding the action and free floating the barrel so that it does not come into contact with the forend, allows the barrel to harmonically vibrate freely and consistently upon firing.

The action screws that hold the action to the stock must also be torqued to the correct weight. If either screw is too loose or too tight, it can cause incorrect tension that can be detrimental to accuracy.

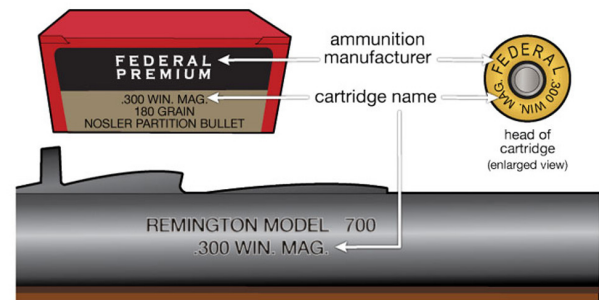

Bedding and floating should be done by a professional gunsmith or gun stock maker. A qualified gunsmith will be able to recommend what work should be carried out on your rifle to gain the best accuracy. Remember some rifles cannot be bedded and/or free floated.

All manufacturers use a data stamp on their rifles and ammunition. On rifles, it is usually located on the side of the barrel near the breech. The calibre is also stamped on the cartridge base and cartridge box.

## Glossary

### Data stamp

Stamp on the firearm's barrel and on the base of the ammunition indicating calibre or gauge.

## Understanding calibre

In most cases, the distance between opposite lands inside the barrel gives us the calibre of the rifle. In the image, the distance between the lands is 243/1000ths of an inch so this is a .243 calibre firearm. Knowing this, we can purchase the correct ammunition for a firearm.

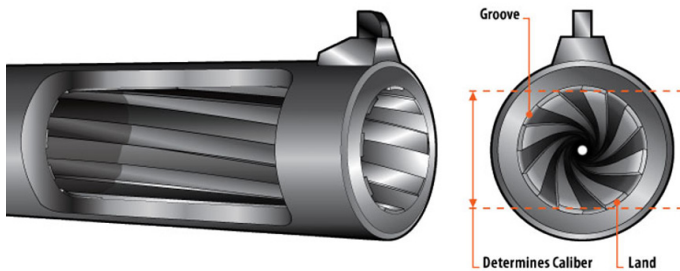

## Glossary

### Land

Raised portion of the rifling grooves.

## How a cartridge is fired

Rifle bores have spiralled grooves cut into the entire length of the barrel (known as rifling), causing the bullet or projectile to spin, which stabilises it as it travels down the barrel.

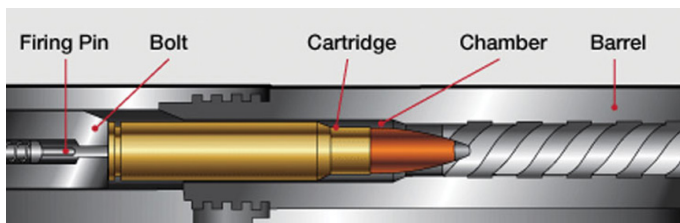

**Step 1:** Cartridge is loaded into chamber.

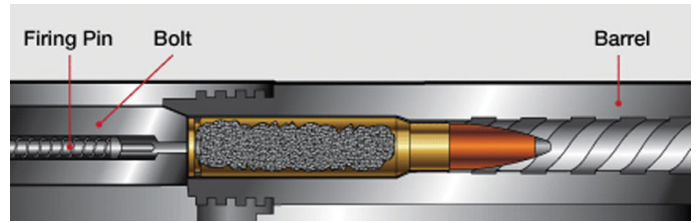

**Step 2:** Action is closed, and the projectile is ready to be fired.

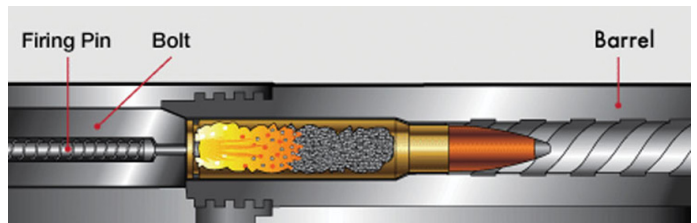

**Step 3:** Firing pin makes contact with the primer and ignites gunpowder, creating high pressure.

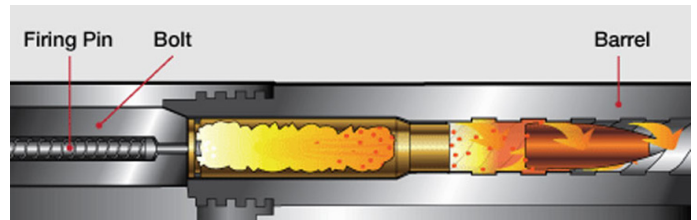

**Step 4:** Rapidly accumulating high pressure from the burning gunpowder pushes projectile out of the barrel.

## How the shotgun is fired

A shotgun used for shotshells features a smoothbore barrel, meaning there is no rifling. When a shotshell is fired, the tiny round pellets travel down this smooth bore to the target. The consistency of roundness of each pellet determines how the pellets fly.

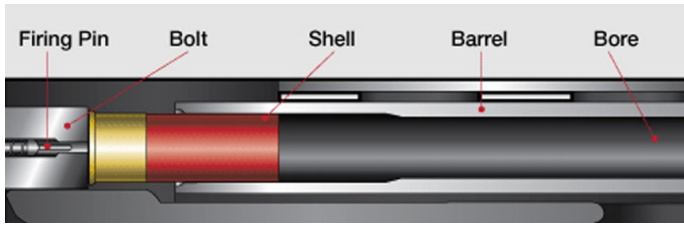

**Step 1:** Shell is loaded into chamber.

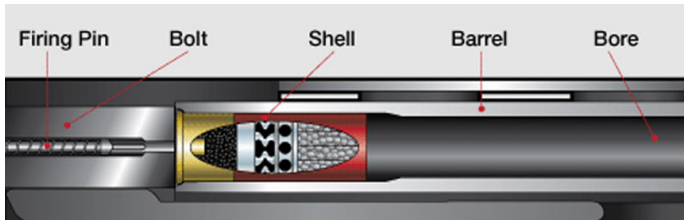

**Step 2:** Action is closed, and the shell is ready to be fired.

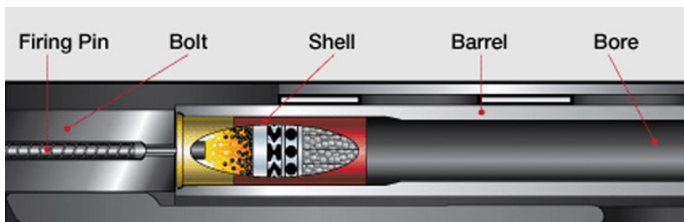

**Step 3:** Firing pin makes contact with primer and causes primer mix to explode in the shell.

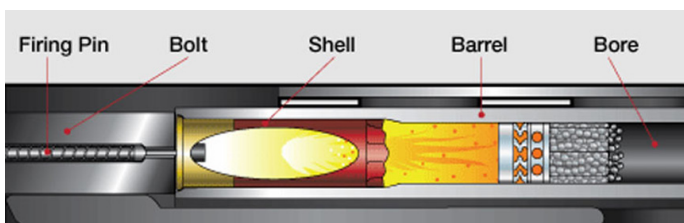

**Step 4:** Rapidly accumulating high pressure from the burning gunpowder pushes projectile out of the barrel.

## Choosing the right projectile

It is essential that you select the right projectile based on its construction and the size of your target animal. When you are hunting small game animals, consider explosive expansion projectiles, such as hollow points or ballistic tips. For larger game animals such as deer, the projectile needs to hold together so it can reach into the chest cavity while at the same time expand enough to double its size and create a massive wound channel. Dangerous game will require a very hard and stout projectile that must smash through thick skin, muscle and bone. These projectiles rely on weight retention to penetrate deep into the vital organs.

### Parts of a projectile

- **Tip:** It is the tip of the bullet that initiates expansion. The tip is driven into the core of the bullet upon impact. The bullet mushrooms, sometimes doubling in size.
- **Core:** Lead is used in the core due to high weight-to-volume ratio and ability to be easily moulded. Alternatively, many manufacturers also produce projectiles which are constructed of pure copper and do not contain any lead.
- **Jacket:** The jacket is designed to hold the core in place and is responsible for weight retention. Specially designed jackets control

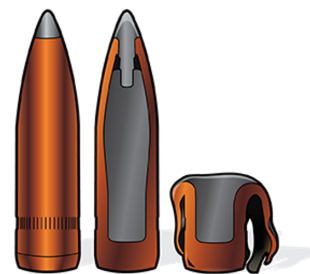

the expansion of the projectile and determine the amount of penetration at recommended velocities.



## Shotshell loads

The weight of the shot charge varies according to the gauge of the firearm and whether it is a hunting or target load. In 12-gauge cartridges, standard shot charges range from 24 to 36 grams. Magnum loads are also available with heavier charges into the 50 gram range.

## Shotshell types

Shotshells are manufactured with either a load of shot or a single slug. Each type of shotshell has a specific purpose.

There are many different shot sizes. The smallest pellets are designed for hunting small birds or pests, and the largest pellets are suitable for game animals at close range. Shot can be made of lead, copper, bismuth or steel.

The hardness of steel can cause serious damage to shotgun barrels and must only be used in shotguns specifically designed for steel shot.

If you are unsure if steel shot can be used in your

shotgun, you should consult a gunsmith. They can provide advice on using other non-toxic shot such as bismuth.

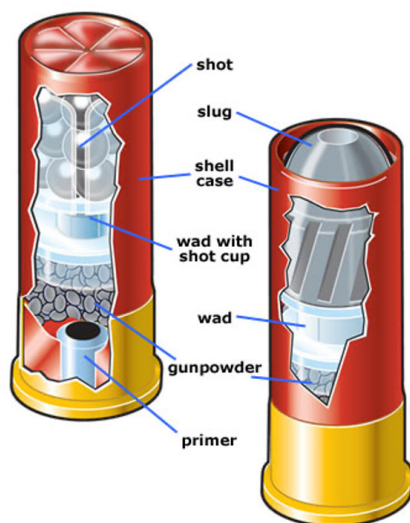

## Solid slugs

For versatility, shotshells that fire a single-rifled slug provide adequate penetration and knockdown power on pig and deer sized game out to a range of 50 metres. These can be fired through a standard shotgun when using the correct choke. They offer better accuracy if the shotgun has a rifled barrel.

## Selecting the correct firearm and ammunition combination

Selecting the correct rifle and ammunition combination for the game animals you are hunting will ensure they are harvested quickly and humanely.

The table on the following page recommends the minimum calibre, cartridge and projectile weight for each game species.

## Glossary

### Calibre

Distance between the opposite lands inside the barrel of a rifle



Species	Recommended Rifle Calibre	Recommended Shotgun Ammunition
Hog deer, Fallow deer, Chital deer, Feral goat and Feral pig	.243 Winchester 80 grain projectile	12 gauge single-rifled slug
Rusa deer, Red deer, Wapiti and Sambar deer	.270 Winchester 130 grain projectile	12 gauge single-rifled slug
Wild dog	.222 Remington 50 grain projectile	Load of 000
Fox and feral cat	.22 Rifle 40 grain projectile	Load of BB
Hare	.22 Rifle 40 grain projectile	No. 3
Rabbit	.22 Rifle 32 grain projectile	No. 3
Duck and pheasant		12 gauge No. 3
Quail		No. 10

## Projectiles for muzzleloaders

Bullets for muzzleloaders are available in different styles, depending on the firearm used and the game you are hunting. Some popular styles include Maxi-Ball and Powerbelt bullets. Consult the owner's manual of your firearm to determine the recommended bullet. Listed here are some of the most common types of bullets.

### Polymer tip sabot and hollow tip

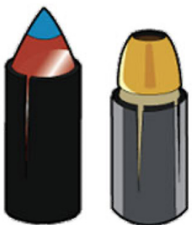

A modern projectile that is available in various styles. The plastic sleeve replaces the traditional patch.

### Cast lead bullet



A modern style of lead projectile.

### Round lead ball and patch

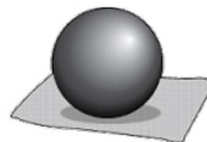

Traditional style of ammunition for all muzzleloaders.

Grain	Description	Use
F	Referred to as single-F. Coarse grain.	Used for shotguns 10 gauge and higher.
FF	Referred to as double-F. Medium grain.	Used in rifles, single-shot pistols (.45 calibre and larger) and shotguns (12-20 gauge).
Cartridge	Medium-fine grain.	Substitute for double-F powder.
FFF	Referred to as triple-F. Fine grain.	Used in rifles and handguns that are under .45 calibre, as well as shotguns smaller than 20 gauge.
FFFF	Referred to as four-F. Extra-fine grain.	Used only to prime flintlock muzzleloaders.

## Propellant

Muzzleloading firearms use a special type of propellant, commonly referred to as blackpowder.

Traditional blackpowder is a corrosive material, which can cause the barrel of your firearm to rust quickly. There are brand-name substitute powders, such as Pyrodex®, CleanShot® and Hodgdon's Triple Seven®. All these powders are safe to use when handled properly. They are sold either in granulated or compressed pre-measured form.

Blackpowder is available in six granulation sizes. The table above lists each grain size, its description and use.

Only use the correct type of propellant for your specific modern muzzleloading firearm. Always follow the manufacturer's instructions for propellants to use in muzzleloader firearms.

CleanShot is a registered trademark of Huntogo. Pyrodex and Triple Seven are registered trademarks of Hodgdon Powder Co., Inc.

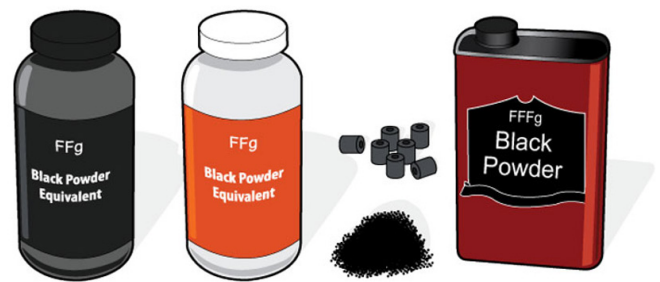



Hunter's tip—Using modern smokeless powder in a firearm that is not designed to handle it can result in serious injury to the shooter and damage to the firearm.

### Important

- Never pour blackpowder into the barrel of a muzzleloader directly from a powder flask or horn.
- There may be a small ember inside the barrel that will detonate the powder on contact. Always use a powder measurer to put blackpowder or its equivalent into the barrel of any muzzleloader.

### Blackpowder primers

Similar to what occurs when firing most modern-style firearms, a primer for muzzleloaders ignites a main powder charge.

The two most common percussion cap primers are the Number-11 Percussion Cap and the 209 Muzzleloader Primer. Each is coated with an explosive substance that, when struck by the hammer, creates a spark. The Number-11 Percussion Cap is placed directly on the nipple and is used for caplock muzzleloaders. The 209 Muzzleloader Primer has a much hotter spark and is used where there is a larger amount of powder in the main charge. It is first placed in a primer holder and then on the nipple.

Always consult the owner's manual of your firearm to determine the recommended primer for your muzzleloader.



### Number-11 Percussion Cap

used for caplock muzzleloaders.



### 209 Muzzleloader Primer & holder

used for inline muzzleloaders.



### FFFFG priming powder

used for priming flintlock muzzleloaders.

### Blackpowder hunting loads

Before heading out to hunt, you will need to work out the best type of projectile for the species you are targeting. You will need to decide between a ball or conical type bullet, as this will have an effect on the accurate range of your muzzleloader.

Once you have decided on your bullet type, patch thickness and type of powder, you will need to visit the rifle range to work up loads in safe increments until you have determined an accurate load for your firearm. Always use safe loads in accordance with the recommendations of reputable hand-loading manuals.

The table on the following page lists recommended calibres and projectiles for different species.

Species	Recommended projectile
Rabbit, hare, fox, feral cat	32 calibre with round ball
Feral pig	50 calibre, 175 grain round ball or 250 grain Minié bullet
Fallow deer or goat, Chital deer and Hog deer, feral goat and wild dogs	45 calibre, 130 grain round ball or 230 grain Minié bullet
Sambar deer, Red deer, Rusa deer and Wapiti	54 calibre, 300 grain Minié bullet



## Loading and firing a muzzleloading firearm

Loading and firing a muzzleloading firearm can be an impressive sight if you have never seen it done before. If you are inexperienced with loading and firing muzzleloading firearms, make sure you have an experienced muzzleloader shooter around to show you and answer any questions you might have. Here is a checklist before you load a muzzleloader.

1. Always read the owner's manual before operating any firearm.
2. Always ensure the firearm is pointed upwards and away from your face and body for loading.
3. Use a stable rest for your firearm so it doesn't tip over.
4. Check to see if the muzzleloader is loaded by inserting a pre-marked ramrod into the barrel.
5. When the mark on the ramrod disappears into the barrel, this means the firearm is unloaded.
6. Begin steps to load the firearm consistent with the manufacturer's instructions.



## Blackpowder safety

Here are some safety considerations when using blackpowder:

- never use 4F powder as a main charge in any type of blackpowder firearm – it is for the pan of flintlocks only
- never smoke when using, loading or shooting with blackpowder, as it may explode
- never load directly from a powder flask or horn into the barrel of a muzzleloader

- always pour powder from a measure into the barrel
- remember, there may be smouldering remnants of powder from an immediate previous shot
- never use smokeless nitrocellulose-based powder in a muzzleloader.



Important – Blackpowder firearms are a possible fire hazard and should only be used in low bushfire danger periods.

## SHOOTING SKILLS

### Proper field carries



#### Two-handed carry

The terrain and the number of hunters that are with you will determine how you carry your firearm in the field.

The two-handed carry provides the best control of the firearm. One hand holds

the firearm's grip and the other is on the forearm of the firearm. This is sometimes referred to as the ready carry. It gives the hunter the best control of the muzzle, and the firearm can be shouldered quickly.



#### Shoulder carry

The shoulder carry is a useful carry when using a break-action firearm. One hand is placed on the barrel as shown, while the action is open and rested on your shoulder. This carry allows for good muzzle control

while walking longer distances. A different type of shoulder carry is used with rifles - where one hand is holding the firearm's grip, barrel resting on your shoulder and the muzzle is pointed behind you. Only use this type of carry if you are absolutely certain that no one is behind you.



#### Trail carry

The trail carry is used only when no one is in front of you. Grasp the stock with one hand, just in front of the action. Ensure the muzzle is pointed away and in front of you. This positions the muzzle toward the ground but does not offer good

control of the firearm. Be careful that the muzzle does not hit the ground - if it does, you have to check the barrel for an obstruction.



#### Cradle carry

Placing the firearm across your chest, rest its action in the bend of your arm. Next, grasp the butt of the firearm with your other hand or cover the trigger guard. The cradle carry is



a very comfortable position. If there is another hunter walking beside you, make sure that each muzzle is pointed in a safe direction.



### Sling carry

The sling carry takes advantage of the sling attachments on your firearm. Attach a sling, making sure it fits, and place the rifle over your shoulder while grasping the sling with your hand. This is a great carry when traveling over long distances. If you bend over to pick up an object, remember that the muzzle is now pointed in front of you.



### Elbow carry

Place the butt of the firearm in your armpit and let the forearm of the firearm rest on your arm. The muzzle is pointed down and in front of you. This is also a very comfortable position but does not give

you very good control of the muzzle. Remember that when you turn right or left, the muzzle will follow you.

## SHOOTING A RIFLE

While shooting at the range or in the field, remember these fundamentals of shooting:

- always follow firearm safety rules
- always wear adequate eye and ear protection shooting a firearm can cause immediate and permanent hearing loss and can damage your vision



- use a steady rest to increase the accuracy of the shot; when in the field, a steady rest could be a stump, log or even your coat
- obtain the sight picture, and hold it
- control your breathing; take a deep breath, and exhale about halfway
- squeeze the trigger with a steady pressure; jerking the trigger will change the sight picture, which will cause the bullet to miss the centre of the target
- after the shot is fired, continue to squeeze the trigger; if you lift your head or jerk the rifle, the shot may be thrown off-target by the movement of the rifle; This waiting period is called the 'follow through'.

## Rifle-shooting positions

There are four standard rifle-shooting positions.



### Prone position

This is the steadiest of all positions, because it supports both the firearm and the hunter's upper body. The hunter's hips and

legs provide a stable platform. This position is very

comfortable and should be used to practice the fundamentals of good shooting.



### Sitting position

This is the next-best position for steadiness. With legs crossed at the ankles, the hunter's knees give support to the arms. But a hunter's legs will start to shake

if this position is held for a lengthy period.



### Standing position (off-hand)

In this position, the hunter's arms are not supported, making it difficult to take an accurate shot. With this position, there is

an exaggerated movement of the barrel. Some hunters will use a tree, fence post or a 'shooting stick' as a prop to help ensure an accurate shot.



### Kneeling position

This position is an adaptation of the standing position in which the hunter places their elbow on their knee to steady the firearm. The hunter

will experience less barrel movement — a key to accurate shot placement.



### Shotgun stance

Your shotgun stance should be similar to that of a boxer — in a standing position with feet apart at shoulder width.

- For right-eye dominant shooters, your left leg will be slightly forwards, and your left foot pointed towards the anticipated target.
- For left-eye dominant shooters, your right leg will be slightly forwards, and your right foot will be turned slightly.

Bend forwards at the waist, and have your front leg slightly bent, but not locked.

Raise the shotgun to your cheek under your dominant eye first and then back to the shoulder. The positioning of the shotgun on your cheek is critical. If the shotgun is not placed correctly against your cheek, your shot will either be high or low.

As a rule, always ensure that the stock is held comfortably — not too tight or too loose — against your cheek, just under the cheekbone. Your head must be held straight and tilted.

Have someone check the fit before you purchase a shotgun. Some shotguns have adjustable stocks to help with this alignment.



## Leading a target

To be able to hit a moving target, you must first learn several firing methods. Each firing method involves you being able to identify a target, shooting ahead of it and following through with the shotgun in constant motion.



## Swing-through method

When using this method, you must consider several factors:

- from clay pigeons to live game, your target has a particular speed
- it will take time to find the moving target in your field of vision and set up for the shot
- once you are in proper stance and you have taken the shot, there is a delay in firing your shot, due to the sequence of the firing pin striking the cartridge, the powder charge igniting and the shot starting to travel down the barrel
- when the shot leaves the barrel, it takes time for it to travel to a target. The farther away a target is from the hunter, the longer it takes for the shot to hit it
- it is very important to continue swinging your

shotgun after the shot for correct follow-through.

Practice this method by following these steps.

1. Once you see the target, start to swing.
2. Swing through target, pull the trigger and continue the swing, spreading the shot in front of the target.
3. The target and shot will come together as you follow through.

## Safe firearm handling

When carrying or passing a firearm, you should:

1. Keep the muzzle pointed in a safe direction.
2. Keep your hands clear of the trigger. This minimises the risk of unintended discharge.
3. Open the action, and check the chamber.
4. Remove any cartridges from the breech (if present).
5. Remove the magazine (if possible).
6. Leave the action open or broken, and insert a firearms safety flag.

When you hand a firearm to somebody, it is polite to show them the opened action. This allows them to see for themselves that the firearm is unloaded. Never rely on the assurances of others. Always check the firearm yourself, each and every time.





## Using a firearm safety flag

Sliding a soft, plastic firearm safety flag into the breech of your firearm shows that your firearm is safe for both the user and others close by. It is simple and effective and will not damage the internal surfaces of your rifle.

To insert a firearm safety flag:

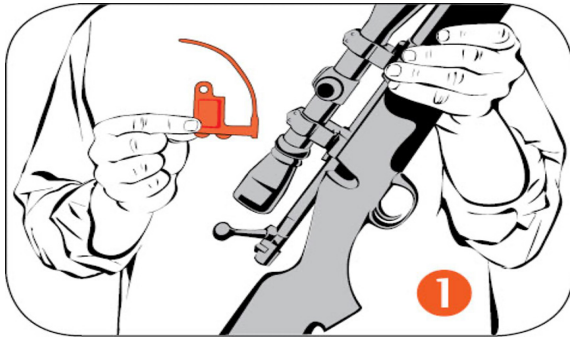

1. Grasp your rifle firmly in one hand, and have the safety flag ready.



2. With the bolt open, slide the firearm safety flag up into the breech.

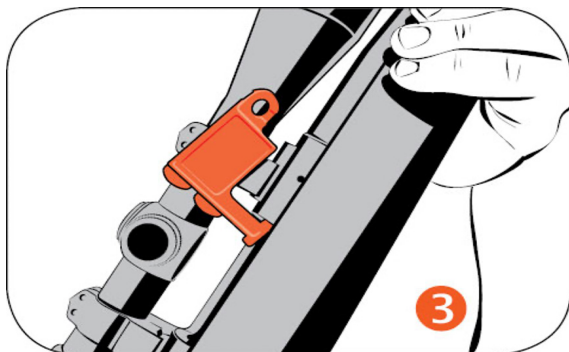

3. Check the flag is securely in place.

## Common firearm malfunctions

### Misfire

This occurs when the trigger is pulled and the firearm does not fire. It is caused either by a weak firing pin or a defective primer that fails to ignite the powder charge.

If you are using a blackpowder firearm, inspect the priming cap or charge. Make sure it is a misfire, and then check that the rifle is loaded correctly using the ramrod.

If you are sure it is a misfire, clean the vent or touch hole with a pick, then re-prime and fire.

### Hangfire

This occurs when the trigger is pulled and the firearm is delayed in firing. It is caused by a temporary failure of the primer to ignite the powder charge.

### Squib load or 'pop fire'

This occurs when the trigger is pulled and you only hear a slight pop and do not feel any recoil. It is usually caused by not having a powder charge in the cartridge or shotshell.



---

Hunter's tip—When any of these malfunctions occur, keep the muzzle of the firearm pointed in a safe direction. Wait 30 seconds, unload the firearm and take it to a gunsmith for inspection and repair.

---

## Transporting your Category A or B firearm when hunting

When transporting a Category A or B firearm on a recreational hunting trip, you must:

- take all reasonable precautions to ensure the firearm is kept safe
- ensure the firearm does not get lost or stolen
- ensure the firearm does not come into possession of a person who is not authorised to possess the firearm
- ensure it is not loaded with any ammunition whilst being transported and that it is not visible from outside the vehicle while being transported.

---

Hunter's tip – General written permission condition 9 explains transport and storage requirements you must comply with when hunting on public land.

---



## Safe storage of firearms during your hunt



At all times when on a hunting trip, you must take all reasonable precautions to ensure your firearms:

1. are kept safe
2. are not stolen or lost
3. do not come into the possession of a person who is not authorised to possess the firearm.

NSW Police Force recommends that, when not actually being used:

- ammunition is stored in a locked receptacle separate from the firearm
- firearms are unloaded
- all firearms are rendered temporarily incapable of being fired, for example, removal of the bolt/firing mechanism or the use of trigger locks or kept in a locked container that is properly secured to, or is within a vehicle.

At no time should a firearm be left or stored unattended or visible in a motor vehicle unless the firearms are stored in accordance with NSW Police recommendations.

DPI Hunting Inspectors will check that all firearms are stored in accordance with the law. Heavy penalties apply for unsafe storage and transportation of firearms in NSW.

### Caring for your firearm in the field

Sometimes you may hunt in less than ideal conditions. Your firearm can be knocked and bumped, or rain and dirt can get into the bolt and action. To keep everything working smoothly and safely, you should assemble a small kit with these items to keep in your pack:

- oiled gun wipes to clean the metal and prevent rust
- bore snake to clear possible barrel obstructions
- lens wipes to clean your optics without scratching
- small tube of gun lubricant to clean sticky actions
- roll of electrical tape to cover the rifles muzzle and prevent obstructions. (**Note:** This is not recommended for shotguns.)

Covering the rifles muzzle with a small strip of brightly coloured electrical tape serves two purposes:

1. To prevent water, dirt or any other foreign body becoming stuck in the muzzle.
2. To reinforce muzzle awareness. The bright colour is easily seen in thick bush or low light conditions.

At the end of each day, it is a good practice to wipe down the firearm to remove any moisture from the metal surfaces and inside the action. Also, check the barrel for any obstructions.



END OF SECTION 2, CATEGORY 1:  
HUNTING WITH FIREARMS





## SECTION 2, CATEGORY 2: HUNTING WITH BOWS



### Introduction and learning objectives

The category objectives are:

- be tested for a NSW restricted game hunting licence (R-Licence) to hunt with bows
- identify archery equipment and know its function
- select the correct archery equipment for your body type, strength and shooting styles
- tune your archery equipment for optimum performance and accuracy
- know the basics of shooting a bow
- determine your effective shooting range
- aim at your target animal to deliver a quick and humane kill
- practice safe archery and bowhunting.

Modern bowhunting is a fascinating and challenging method of hunting that dates back to the Stone Age and can be traced throughout history in many regions around the world. Early humans were skilled bowhunters. Although their bows and arrows were often crude and simple tools, they overcame the limitations of their equipment with their exceptional ability to stalk

within close range of wary prey.

Even with modern technological advancements in equipment and hunting techniques, bowhunting is still essentially a short range hunting method. The challenge for bowhunters is to not only master the shooting of the bow and arrow but also develop the hunting skills necessary to overcome a game animal's highly evolved senses of sight, sound and smell.

Bowhunting has proven to be a humane and effective method of harvesting targeted animals when used within the effective range of the equipment.

The ability to get close to game remains the essence of all types of bowhunting today.

### Bowhunting ethics

In Unit 3 of Section 1: Be an ethical and involved hunter, we explored what being an ethical hunter is all about. These moral codes are vitally important and should always be front of mind.

Your ethical code doesn't just happen all by itself. Thinking about what you consider right or wrong is important.



Consider how you would feel after acting on a decision — would you feel proud or ashamed? And how would it affect other people?

To make ethics work for you, there are four steps to follow.

1. Have the correct licences and permissions to hunt.
2. Realise that there are moral decisions to make for many of your actions, such as: ‘Should I shoot now and risk merely wounding the game, or should I wait for a better shot?’
3. Think about the consequences of those decisions and how they might affect you and others.
4. Do the right thing.

That sounds simple; in real life, however, few answers are black and white. Your personal ethics will help you sort through the grey areas and any moral dilemmas you might encounter.

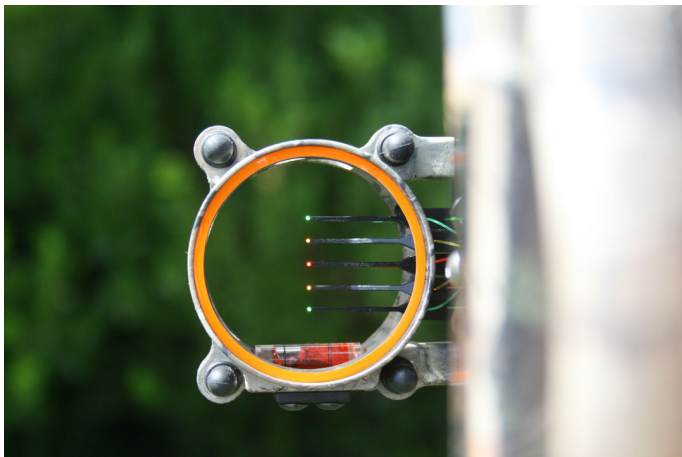

## KNOW YOUR ARCHERY EQUIPMENT

### Introduction to types of bows

Modern bowhunting is a fascinating and challenging method of hunting.

It has proven to be a humane and effective method of harvesting targeted animals when used within the hunter’s skillset and the effective range of the equipment.

Even with modern archery equipment and hunting techniques, bowhunting is limited to short range hunting. The challenge is to get as close as possible before taking the shot. Bowhunting is not for all hunters. It requires a high degree of patience and perseverance to be successful. In general, there are three basic types of bows. Let’s take the time to look at each type.

Longbow



Recurve Bow



Compound Bow



## Compound bow

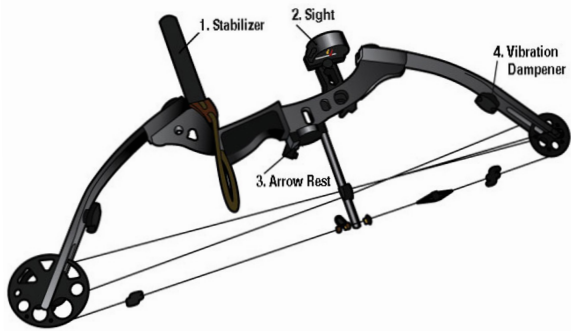

The compound bow is the most popular choice amongst archery hunters and revolutionised modern bow hunting. It is characterised by having two wheels or cams located on the ends of the limbs. Utilising a system of cables attached to the wheels or cams, the bow is drawn back towards the archer's face.

With longbows and recurve bows, the further the string is drawn back, the more energy and strength are required to hold it back. This can make aiming more difficult. The design of the compound requires most draw effort at the beginning of the draw rather than at the end and so, as the wheels or cams roll over, the draw weight at full draw can be reduced to less than 70% of the peak draw weight. This makes the bow much easier to aim and shoot. This also allows the bow's limbs to store more energy, increases arrow velocity and flattens the trajectory of the arrow, which makes it more accurate over longer ranges.

This bow type is the easiest to master and considered to be the most accurate.

## Parts of a compound bow

Here are the parts of a compound bow.

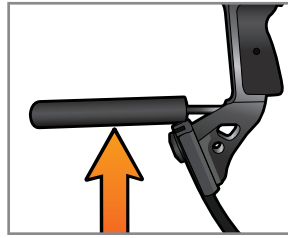

### Stabiliser

Adding a stabiliser adds forward weight, to balance the bow and absorb the vibrations when the string is released.

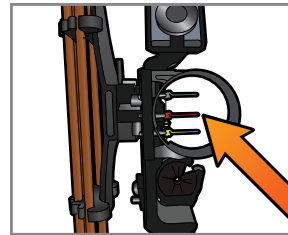

### Sight

A mechanical device to help the bowhunter to place a shot.

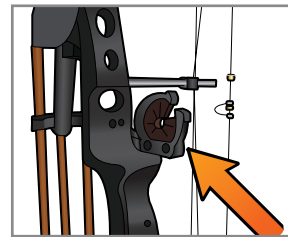

### Arrow rest

A device that holds the arrow above the arrow shelf.

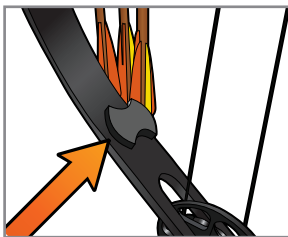

### Vibration dampener

This will help absorb vibration caused when firing the bow and will also help reduce shock and excess noise.

## Longbow

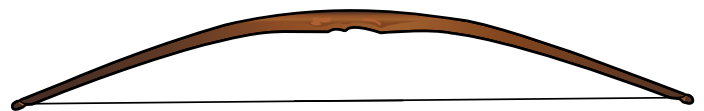

The longbow is a large, powerful, lightweight bow. For a novice archer, it is more difficult to use than other bow styles. Not all longbows have an arrow shelf for an arrow rest, nor do they shoot as fast



as the recurve or compound bow. It also does not have a 'let-off point'. This means the archer feels the total draw weight of the bow through the entire process. When the string is drawn back, energy is stored in the limbs until the archer releases the bowstring, propelling the arrow to the target at high speed.

Bowhunters who prefer a more traditional hunt with the recurve and longbows may have the least possible accessories or additional parts on bows in order to increase the challenge when hunting. Bowhunters who use the compound bow, by contrast, may add several accessories to support more accurate and quiet shooting. Whichever bow you choose to use, remember to always follow manufacturer's instructions for safe handling and use of your bow.

## Recurve bow



The recurve bow features limbs that point away from the shooter when the bow is strung. The string sits in a notch along the back of the limb and only comes away from the limb when the bow is drawn.

It is easier for the novice archer to use, since its curved limbs give it more potential energy.

When pulling back a recurve to a full draw, the archer experiences less hand shock and vibration than with a longbow. However, unlike the compound bow, this bow does not have a 'let-off point', that is, the archer will still feel the total

draw weight of the bow throughout the entire process. When the string is released, the limbs and string move in a forward direction. The stored energy in both parts of the limb is released very quickly, propelling the arrow towards the target at high speed.

## Parts of a bow

Here are the common parts on a bow.

### Grip

The grip allows the hunter to hold the bow in a vertical position while shooting. For bows with a wrist strap, the proper way to grip is with a relaxed handgrip. For other types of bows, the fingertips are curled, resting lightly on the front of the grip. The force of the bow, at full draw, pulls the grip into the palm of the archer's hand. If the archer grips the bow too tightly, it tends to throw the arrow off target.

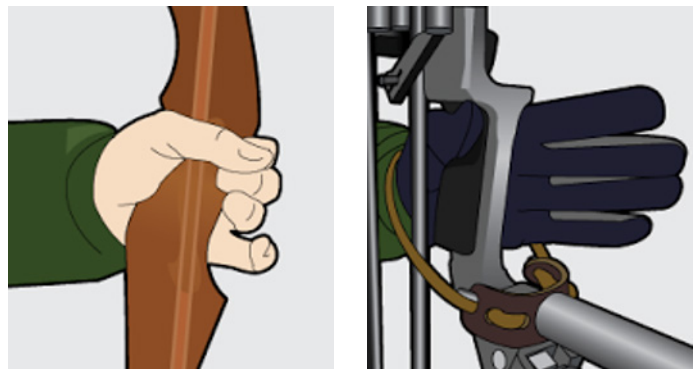

### Limbs

The limbs form the upper and lower part of the bow that bends when the string is drawn back. The limbs store the energy when the bow is held at full draw. Never release a bowstring without an arrow nocked in place. This is called 'dry firing' a bow. Doing so can cause serious damage to the bow and/or injury to the shooter and bystanders.



### String groove

The string groove is found on the limb tip of longbows and recurve bows. The groove keeps the bowstring in place.

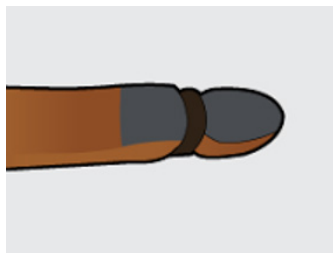

## Parts of a bow string

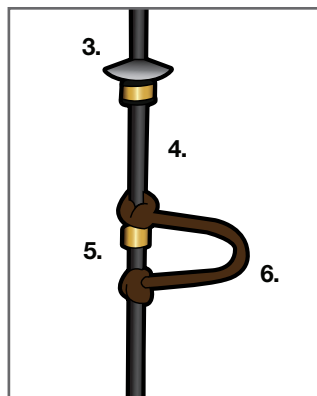
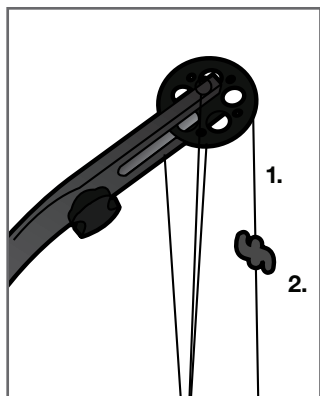

### 1. Bow string

The bowstring attaches to the limbs of a longbow or recurve bow or attaches to the cable for a compound bow. It also has a centre nock locator for nocking (positioning) an arrow.

### 2. String silencer

The string silencer is an elastic material to damp-

en the vibrations in the string, resulting in a reduction in string noise and vibration. A string silencer is not used on a longbow.

### 3. Kisser button

The kisser button is a small plastic button that attaches to the bowstring. At full draw, it will touch the archer's lips to provide another point of reference for the anchor position.

### 4. Serving

The serving is the wrapping of material in the centre of the string to protect the string from wear. The nock locator attaches to the serving.

### 5. Nock locator

The nock locator is a mark or device that indicates where the arrow is to be placed on the string. It is located on the serving area of the string.

### 6. Release aid loop

A release aid can be used in combination with a mechanical release for a more accurate shot.

## Releases and arm guards

### Releases

With the heavy draw weight of today's bows, most people choose to use some sort of release to protect their fingers and increase accuracy.

- 1. Mechanical release:** This functions like the trigger on a gun and provides a decisive, frictionless release of the string for greater accuracy.
- 2. Shooting glove:** A glove-like attachment for the shooter's hand that can support a smooth release of the string while protecting your fingers.

1



2



### Arm guards

Arm guards are available in various shapes, sizes and designs. They are used on whichever arm is holding the bow to help keep loose clothing tucked away and to help prevent 'burning' from the friction of the bowstring rubbing against the arm when it is released. A proper stance or position by the shooter will also help prevent the released bowstring from 'burning' the arm holding the bow.

- 1. Large surface arm guard:** This will help keep clothing tucked away.
- 2. Lightweight arm guard:** The design allows ventilation when hunting in warm weather.

1



2

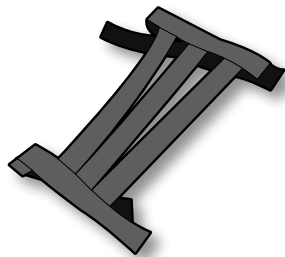

### Parts of an arrow

Arrows can be made from wood, fiberglass, aluminium or carbon. All arrows share the following five parts.



Important – A wooden arrow cannot handle the extreme pressure of a compound bow. It could shatter, causing damage to the bow and possibly injuring someone.

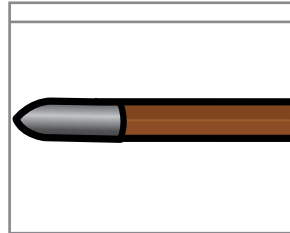

**1. Arrow point:** This is the point or tip of the arrow. The particular arrow point you choose is determined by the game species you will be hunting.

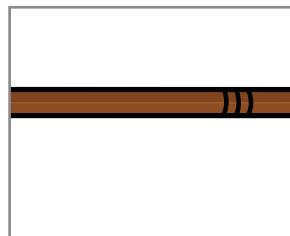

**2. Arrow shaft:** This is the main structural component of the arrow, to which all other parts are attached. The stiffness of the shaft is called the **spine**. Make sure the arrow is matched to your bow's poundage and your draw length.

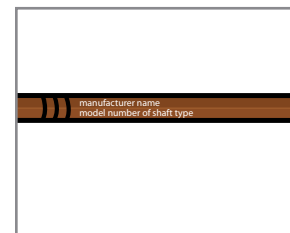

**3. Crest:** The markings on the crest indicate the manufacturer of the arrow, the model number of the arrow shaft, and in some cases, the specific arrow measurements for the diameter and thickness.

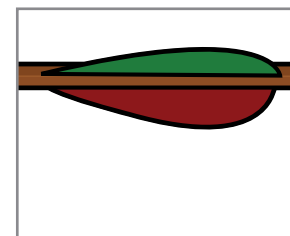

**4. Fletching:** Constructed either of plastic or real feathers, fletching provides stability for the arrow when in flight. There are usually three or four vanes per arrow.

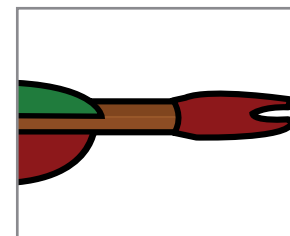

**5. Nock:** Generally constructed from plastic, featuring a notch in one end to attach the arrow to the string.



## Covered quiver

All arrows should be carried safely in a covered quiver. Covered quivers are a convenient and easy way to carry your arrows, giving you quick access while protecting the broadheads and preventing injury. Certain types of quivers can also protect both the arrows and fletching from damage.

Before hunting, ensure that all your equipment is in good working condition. Cracked arrows should be destroyed first and then discarded. Check for frayed bowstrings and replace any bows that have cracked or twisted limbs.

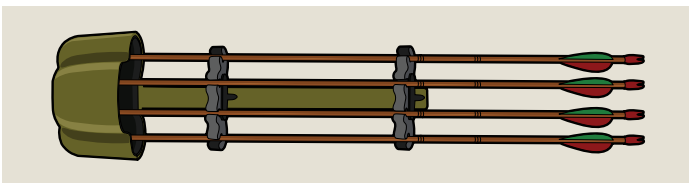

## Types of arrow points

Let us review the various types of arrow points available.

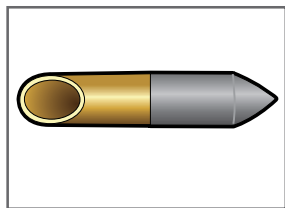

**Bullet points:** They are used for target practice. Blunt points: They are used for small game and are made of metal or rubber.

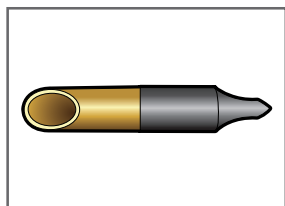

**Field points:** They are used for target practice and small game hunting.

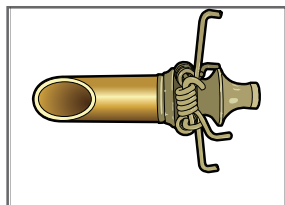

**JUDO points:** They are used mostly in grassy areas for small game.

JUDO is a registered trademark of Zwickey Archery Inc.

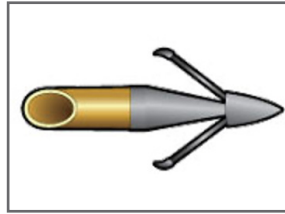

**Fishing points:** They are used for bowfishing and feature barbs to hold the fish to the arrow.

## Broadhead selection

Broadheads are the arrow points used for hunting. They are designed to fly accurately, penetrate deeply and cut vital organs to facilitate a quick and humane kill.

There are three types of broadheads:

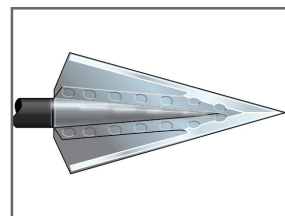

**1. Fixed blade design:** These have two or more blades that need to be manually sharpened.

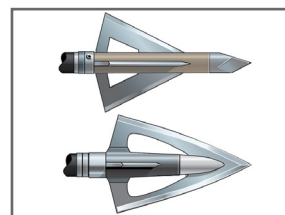

**2. Replaceable blade design:** These have blades that are pre-sharpened in the factory to a shaving sharp edge and can be

replaced after the shot.

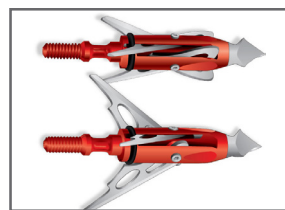

**3. Mechanical broadheads:** These blades are folded into the head and produce less drag during flight. Upon impact, the blades

rapidly expand, cutting a much larger area than fixed blade broadheads, producing a greater wound channel.

Two-bladed broadheads provide the best penetration and are suitable for hunting all animals. As the number of blades increases, there is a corresponding decrease in penetration due to the drag of the extra blades, although this can be

offset with an increase in the size of the wound channel and ability to sever tissue. Generally, bows of lighter weight should use two-bladed broadheads, and those hunters using heavy-weight bows can choose to use broadheads with more than two blades.

## How broadheads work

Broadheads kill by causing massive haemorrhage. Animals shot in the chest vital zone will die quickly and humanely. This area of the animal's body

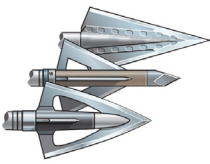

provides the largest target area of vital organs and so provides the greatest opportunity to achieve a humane kill.

When a shaving sharp broadhead hits an animal through the chest, it causes a massive amount of blood loss. This blood loss rapidly decreases the animal's blood pressure, rendering the animal unconscious and resulting in a quick and humane death.

Shaving sharp broadheads are essential as they:

- cut through skin, muscle and soft bone better than dull ones, providing deeper penetration
- cut the tough elastic walls of blood vessels better and cause more bleeding than dull broadheads
- are more likely to penetrate an animal completely, which leaves both an entrance and an exit wound, making trailing and recovery easier.

---

Important – Always use a broadhead wrench when adding or removing a broadhead point. Be careful! The points are very sharp.

---

## Selecting a bow and arrows

DRAW	29"
WEIGHT	60#
STRING	90.75"
CABLE	34.50"
SERIAL #	123-4567

A bow must fit the individual who shoots it.

Likewise, arrows must be sized for the bow. Before attempting to shoot a bow and arrow, get familiar with the bow's draw weight and draw length. These figures are always quoted in inches (") and pounds (lbs or #) .

### Draw weight

Draw weight describes the maximum amount of weight needed to pull a bowstring completely back. The draw weight is measured in pounds. When purchasing a bow, be sure you can pull it back comfortably.

The bowstring should be pulled back in a smooth motion to full draw. If you have to struggle, the draw weight is too high and will result in poor shot placement.

---

Hunter's tip – Drawing back a bow that has too much draw weight may result in pulled muscles in your chest and shoulder areas or other damage to your shoulder.

---

### Draw length

Draw length describes the distance between the bowstring and the grip at full draw. Bows come in different draw lengths, the most common being within the 26 to 29 inch range. When purchasing

a bow, it is very important to have it properly fitted by a reputable dealer. Every bow has a label describing how the bow is set up, with the string and cable length. It is usually located on the inside of the lower limb.

---

Important – Drawing a bow back that does not fit your draw length may result in damage to your bow.

---

### Conversions:

29" = 74 centimetres

60 lbs = 27 kilograms

## Correct bow shooting technique

Here we will explain the correct technique for shooting a bow. You may need to alter these steps to suit the type of bow you are using.

### Step 1: Stance

There are three basic stance positions to consider.

1. **Squared stance:** Feet are in-line with one another, drawing a line perpendicular to the target.
2. **Closed stance:** Front foot is forward from the front of the body.
3. **Open stance:** Front foot is slightly pointing towards the target.

Regardless of which stance you choose, it should be comfortable and solid. Start by placing your feet about shoulders-width apart with your body weight distributed evenly between your lower back and the heels of your feet.

Most bowhunters commonly use the open stance, which starts by positioning your toes at 90 degrees towards the target. Then take a half-step backwards with your leading foot.

This stance essentially places the chest more towards the target and allows for greater bowstring clearance along the bow arm and chest.



### Step 2: Grip

Keep a relaxed grip on the bow. Resist the urge to tighten your fingers around the bow. Instead, let your fingers naturally drop around the handle. This will eliminate unwanted torque and cam-lean, which result in the bow slanting to one side.

Your wrist should be slightly bent upwards and outwards with the main pressure point of the riser being somewhere in the joint between your thumb and index finger. This grip will form a natural pocket.

If your knuckles look white from a tight grip, you are not holding the bow correctly. Remember to keep your fingers loose and relaxed.

### Step 3: Drawing the bow





Contrary to popular belief, drawing a bow



incorporates all the muscles used in keeping your form correct and mainly uses the back muscles.

When drawing the bow, start by keeping your elbow high and in line with your jaw. Begin drawing the bow by pulling straight

back, using your back muscles and not your bicep muscle.

The hand that is gripping the bow should be directly in line with your shoulder at full draw. Also your drawing hand and elbow should be at level with each other.

Some archers feel more comfortable if the elbow is slightly higher than the shoulder and the forearm is level with the arrow at full draw.

#### Step 4: Anchor point

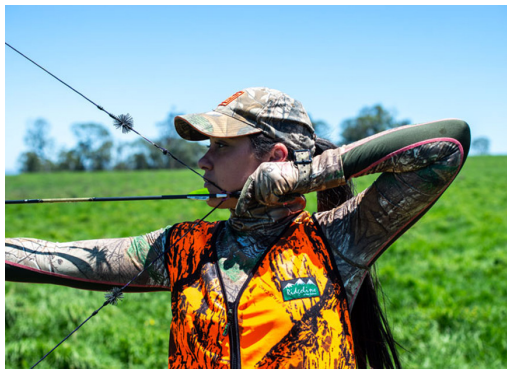

An anchor point is a spot that is touched by the draw hand or string when the bow is fully drawn and ready to shoot, usually a point on the archer's mouth, chin, jaw or nose.

By continuously using the same anchor point or points, the archer has a better chance of reproducing the same shot each and every time.

#### Step 5: Follow through

Follow through is vital for accurate shooting. It requires the archer to hold the bow arm in the same position as just prior to the shot, until the arrow reaches its target. It takes the arrow a split second from release to clearing the arrow rest. Any movement of the bow arm or body during this time will greatly affect the impact point of the arrow.

#### Setting up your bow

Before shooting, make sure the target is placed in a safe spot. Check behind target for a suitable backstop such as a hill or dirt pile.

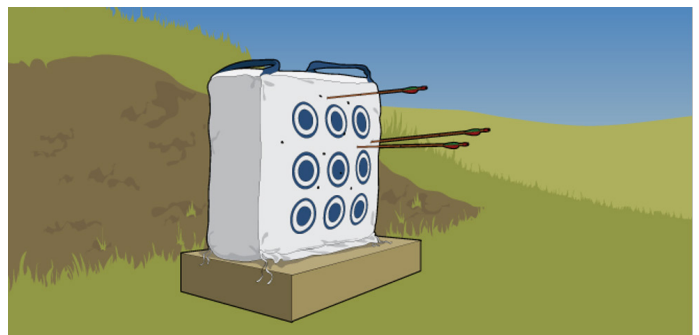

Grasp an arrow just in front of the fletching and place it on the arrow rest. Line up the slot of the nock, ensuring the fletching is in the correct position for your arrow rest. Gently push the nock onto the string under the nock locator until you hear a click. This is called 'nocking the arrow'. Assume a shooting position, looking at the target. You can aim either by choosing your target instinctively or by attaching a mechanical sight to the bow for reference.

Pull smoothly at the bowstring to a full draw, anchoring the string to your anchor point. In a smooth motion while keeping your bow arm steady, release the string and hold your shooting position until the arrow hits the target.

Bowhunters practice on a regular basis to maintain a high level of skill with shooting their bow. They will practice in conditions similar to those that are likely to be experienced in the field; with target arrows and also with the particular kind of arrow point they tend to use for hunting, as for example, the broadhead for hunting larger game, like deer.

## Recommended minimums

The following equipment minimums are recommended to ensure that bowhunters humanely and effectively harvest their target species.

### Arrows

- all arrows must be equipped with a broadhead of not less than 25 millimetres in width
- all broadheads must have a minimum of two sharpened cutting blades.

### Draw weights

All draw weights apply to peak draw weights of longbows, recurve bows and compound bows.

Species	Minimum draw weight
Rabbit, hare, fox, feral cat	30 lbs (13.5 kgs)
Wild dog, feral goat	40 lbs (17.5 kgs)
Feral pig, chital deer, fallow deer	45 lbs (20.0 kgs)
Rusa deer, red deer, sambar deer, wapiti	50 lbs (22.5 kgs)
California quail, partridge, pheasant, peafowl, turkey	45 lbs (20.0 kgs)

## Bow shooting techniques

Depending on the type of bow being used, hunters will generally use one of two shooting techniques.

- Bare bow shooting, where there is no sight attached to the bow.
- Sighted shooting, where a mechanical sight is attached to the bow and allows the hunter to accurately shoot at pre-set ranges.



### Bare bow shooting

This technique requires very regular practice, often daily, to reach and maintain an acceptable level of accuracy. It involves becoming familiar with the equipment and trajectory of the

arrow that it becomes an extension of your body. Many traditional bowhunters practice this style of shooting.

### Sighted shooting

A sight is fixed to the bow's riser and, in some instances, the bowstring as well. The sight pins are adjusted to pre-set distances for each bow. Once the distance to the target is estimated, the bow is drawn, and the correct sight pin is placed on the target before the arrow is released.

Generally, these sights come with one to five coloured fibre optic pins that the hunter can set at distances they are comfortable shooting at.



Each pin is adjusted in the same way a rifle scope is sighted in. The hunter will need to shoot three to five arrows to confirm acceptable groupings.

## How arrows and bullets differ

To understand the importance of proper shot placement and recovery techniques, it is helpful to know how arrows and bullets differ in the way they impact and kill an animal.

- Bullets kill by high-energy impact that crushes tissue and bone; bullets may knock down an animal or incapacitate it by breaking major bones; this reduces the animal's chance of running away.
- Broadhead-tipped arrows deliver a low-energy impact that kills by cutting vital tissues. Because impact alone won't knock down an animal, the arrow must be placed properly for a quick kill and easy recovery. A poorly placed arrow will have little immediate impact, making it difficult, and perhaps impossible, to recover the animal.
- In addition, arrow wounds are generally less painful and generate less fear and panic than a comparable bullet wound. This is important

to remember because patience in the recovery process often means that an animal — if mortally wounded — will die relatively close to where it was hit if it isn't spooked.

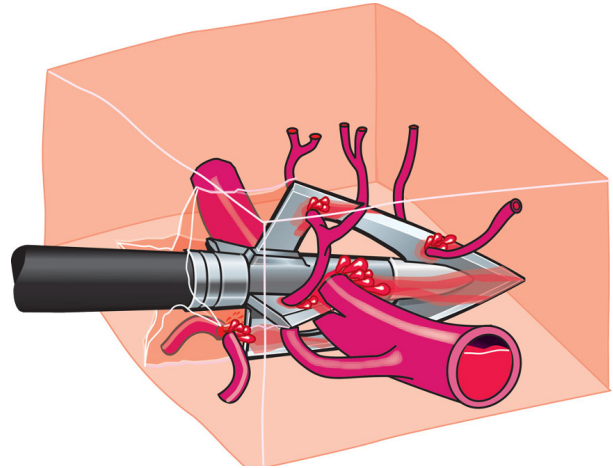

## Animal welfare and shot placement

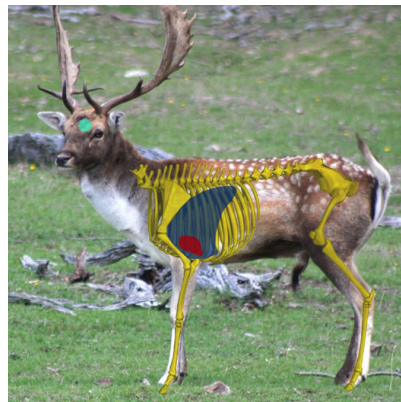

Proper shot placement is critical in bowhunting because an arrow must be placed precisely for a quick, clean kill.

The responsible

bowhunter only takes a shot that can strike the chest vital zone of the animal reliably and passes up any other shots. Merely wounding an animal is a serious error that can be avoided if the bowhunter knows the vital area of the targeted animal.

There are serious legal implications for any bowhunter who breaches the Game Hunting Licence Code of Practice or the *Prevention of Cruelty to Animals Act 1979*.



## When to shoot

A game animal rarely offers the ideal target: broadside shot, within range, in the clear and unaware of your presence. Therefore, you will need to practice to make more challenging shots. You also must learn to recognise the right moment to shoot. Take your best shot when the time is right by following these steps.

- Move into shooting position when the animal is facing away from you.
- Wait for the right moment.
- Only move when the animals focus is elsewhere, such as feeding or looking in another direction.
- Make your move to full draw, and then wait until the animal stops near your pre-selected 'shooting' spot. (If you cannot move to full draw without exposing yourself to the animal, wait motionless until the animal has passed by before making your move into the shooting position.)
- Focus on the aiming spot over the animal's vital area.
- Relax and take the shot.
- Continue to aim after the shot until you see the arrow hit the target; 'peaking' or dropping your bow arm will cause erratic arrow flight and affect the point of impact.

---

Important – Never assume that a shot has missed the animal. Always check the area for signs of a hit and remember your obligation to track any wounded animal under the NSW Game Hunting Licence Code of Practice.

---



## After the shot

A bowhunter must gather a variety of 'hit data' to help track the animal after the shot. The first important piece of information for a successful recovery is noticing where your arrow strikes the animal. Using fluorescent coloured nocks and veins can help with seeing your shot placement. Knowing where your arrow hit is a good indicator of:

- how long it will take your animal to die
- how long to wait before beginning the recovery process.

To track your arrow after release, remain perfectly still and remain in your location until the animal has fallen or is out of sight.

In addition to noting where the arrow strikes, notice:

- how far the arrow penetrates — in some cases, it may pass through
- where the arrow hits the ground if it passes through the animal
- how the arrow strike sounds — a 'crack' may indicate a broken bone, a 'thud' may signal

a solid chest hit and a ‘plop’ may indicate a gut shot, or you may hear the arrow slapping branches

- how the animal reacts after the strike — does the animal collapse instantly, run away or hump up and walk away? if the animal humps up, there is a high likelihood of a gut shot
  - if the animal instantly collapses (spine shot), immediately shoot it again
  - if the animal remains upright and leaves the area:
  - watch it as long as possible to determine the direction of travel
  - listen as the animal flees — you may hear it fall to the ground; also listen for groans, breaking brush or rolling rocks
  - note the time, landmarks around the shooting area, and where the animal was standing or last seen
  - mark your location on your GPS enabled device.



## Be patient



If you have made a successful shot, the animal should die within 30 seconds. An animal hit with a less than perfect shot can travel a great distance before collapsing.

Bowhunters should be patient and allow

the broadhead to do its work before approaching or trailing the animal. Approaching a downed animal or starting the tracking process too soon may cause it to run even farther away, making the recovery more difficult. Usually you will find a well-hit animal within a few hundred metres. A poorly hit animal may travel considerably farther, but never give up while there is sign to follow.

If it appears that the arrow penetrated deep into the chest, wait 20 to 30 minutes to give the animal a chance to bed down and die. Then follow the trail carefully.

If you find the arrow with signs of a gut hit and lacking a decent blood trail, back off and wait six to eight hours before trailing, or you could risk pushing the animal into areas where recovery is impossible.

When in doubt about where you hit the animal, it is better to wait 30 to 60 minutes and then carefully start trailing the animal. If you are new to trailing and recovery, it is best to have a more experienced hunter with you.

## Know what to look for



After you have waited a sufficient amount of time, move slowly and quietly from your shooting position to the area of your shot. Approach carefully to avoid destroying any important game sign. Look carefully for blood, hair or your

arrow if you think it passed through the animal, realising that the arrow can be buried under leaves, grass or dirt. Inspecting your arrow can help you confirm the type of hit.

- Using paper or tape, mark the position of the animal when the arrow was released and also your location when you fired.
- Note the reaction of the animal when hit with the arrow and its direction of flight.
- Look for signs of blood, hair and the arrow itself on the ground.
- Mark the location of blood with the paper or tape to provide a line of travel of the animal in case the blood trail is lost; if you lose the blood trail, go back to the last blood spot and look in widening circles until more blood or sign is located.
- If a good blood trail suddenly ends, look carefully in any thick cover or bushes that the animal may have bedded in.
- In steep or hilly country, animals generally head downhill when shot.
- Tracking should always be done slowly and

carefully. It is important to spend as much time looking forward as looking on the ground.

- Using the help of another hunter or a tracking dog will increase the likelihood of finding the animal.

## Blood sign

Blood sign can offer important tracking clues, such as blood splashes in the direction the animal is travelling.



- The colour, appearance and location of fresh blood can indicate the type of hit:
  - bright red blood indicates bleeding from arteries; darker blood indicates bleeding from veins
  - blood that has bubbles or looks frothy could indicate a lung hit
  - fluid that is greenish, has gut material, or is clear can indicate an intestinal shot.
- Dried blood usually has a brown colour and can be difficult to spot on brown grass or leaves.

## Lost sign

If all sign is lost, don't give up.

- Go back to your last marker and begin a



methodical search of the surrounding area. Some hunters will search in ever-widening circles. Another method is to grid off the surrounding area in squares and to search each one. You may need to get down on your hands and knees to inspect every detail in the area closely.

- Look for obvious escape routes such as trails, especially those heading downhill or towards water.
- Take careful note of your surroundings, and use your GPS to mark your location before you start your recovery effort. Look around the surrounding area for game trails, openings in fences, thick cover – anything that could provide an escape for an injured animal.
- If necessary, you may need to go back and start your search from the beginning. Don't give up until all possibilities have been exhausted. A responsible hunter will make every legal effort to recover the animal.



**END OF SECTION 2, CATEGORY 2:  
HUNTING WITH BOWS**



## SECTION 2, CATEGORY 3: HUNTING WITH DOGS



### Introduction and learning objectives

For centuries, dogs have been used to hunt various types of game animals. Today, hunting with dogs is still a very popular recreational hunting technique for obtaining food and to reduce populations of pest animals which benefits both landholders and the environment.

Hunting with dogs is a safe and legal activity when carried out responsibly. It is very important that hunters using dogs know, understand and comply with the legal and animal welfare requirements. These requirements apply to hunting with dogs, to maintain community confidence and to build upon the social licence and reputation of responsible hunters. The category objectives are:

- apply for a NSW restricted game hunting licence (R-Licence) to hunt using a dog
- understand hunting dog types and suitability
- value the importance of dog training and obedience
- apply your knowledge and obey the law when

hunting with dogs

- understand the laws relating to hunting with dogs at night on public land
- use the right safety equipment
- know how to care for your hunting dog.

### Legal activities

A NSW R-Licence with the dogs category along with Written Permission, issued by the Department of Primary Industries (DPI), allows you to use a dog while hunting on public land in the following capacities:

- game animal hunting using gundogs
- pig hunting
- mustering goats using working dogs.

To harvest or capture any animal on public land for the purpose of selling the meat or any other part of the animal, including if mustering goats using dogs, you must hold a commercially qualified NSW R-Licence (R-Commercial). Extra requirements, such as having the firearms category and permission to operate commercially on public land, must be met before applying for an R-Commercial Licence. These requirements are listed on the DPI Hunting website.



## Choosing the right dog

Traditional hunting dog breeds display specific traits, behaviours and instincts specific to their intended purpose. Before choosing your type of dog, you must be able to identify your hunting purpose, in order to determine the most suitable breed for you and your lifestyle.

Dogs used to hunt birds and small game are generally sporty dogs that are eager to please their handler. Their innate willingness to flush, point and retrieve also makes them easily trainable.

Dogs used to hunt large game, such as pigs, must exhibit specific skills and be able to work as a team. These dogs are often athletic, lean, fast and muscular and must be able to securely bail and hold a pig for humane dispatch.

There are many things you must consider before buying a dog.

- Why do you hunt?
- What is your preferred hunting method?
- What type of animals will you be hunting?
- What environment will you be hunting in?
- Will this be your only dog?
- What type of dog will best suit your family?
- Who will be primary caregiver for the dog?
- How much exercise and attention will your dog need?

Answering these questions will help you choose the right dog for your preferred type of hunting.

---

Important – Any dog that is overly aggressive should never be used for hunting.

---

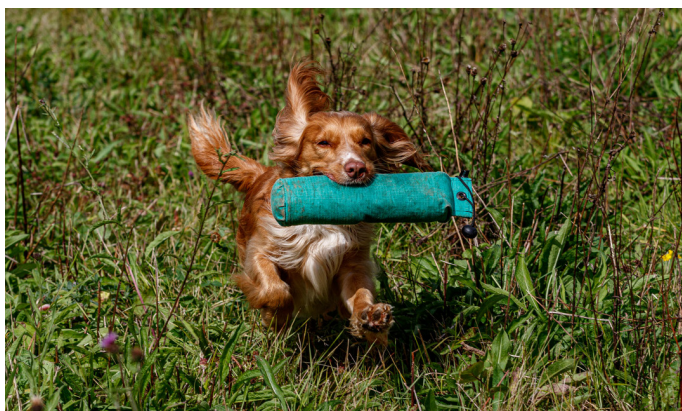

## MATCHING A BREED TO YOUR HUNTING PURPOSE

### Gundogs

Gundogs assist hunters in finding and retrieving game. They have been selectively bred over centuries to produce bloodlines capable of controlled and methodical field work, with a perfect balance of trainability and temperament. Gundogs must have the instinct, drive and energy to perform certain tasks in the field.

All gundogs must be soft at mouth, that is, any game they retrieve is returned to the hunter with minimal damage and is fit for the table.

Different breeds excel at different tasks, which is why your preferred hunting method will determine which type of gundog you should choose.





## Gundog tasks

Here are the four main gundog tasks.

**1. Pointing:** Pointing breeds are commonly used for hunting birds, such as quail and pheasants.

The dog will run out in front of the hunter in a wide circle and try to locate game birds by scent.

When a dog is at point, it freezes, points its nose in the direction of the bird and holds up one of its front legs. The dog remains motionless until the hunter steps forward and flushes the bird into the air for a shot. Once the bird is down, the dog is commanded to retrieve.

Some of the well-known pointing breeds are:

- German Shorthaired Pointer
- Wirehair Pointer
- Gordon Setter
- Irish Setter.

Pointing breeds are also becoming increasingly popular with deer hunters, as they are very effective at locating and pointing elusive deer.



**2. Flushing:** Spaniels are a dedicated flushing breed and have a natural ability to locate, point and flush game birds. They rely heavily on their nose to scent birds and small game in tall grass. They hunt within shotgun range of their handler, working from left to right until a bird is found.

As a bird is flushed, the dog will immediately sit and observe the flight path. Once the bird is downed, the dog will mark the spot and retrieve upon command. Some of the common breeds are:

- English Springer Spaniel
- Cocker Spaniel
- Water Spaniel.

**3. Retrieving:** Retrievers get their name from their ability to retrieve game birds, usually waterfowl, that have been harvested by a hunter.



The dog is expected to remain still and calm as the ducks approach the blind. A well-trained retriever will watch and follow the hunter's gun and mentally mark the location of each downed bird. Upon command, the dog will retrieve each bird and must also be able to respond to signals from the

hunter. Some of the common retriever breeds are:

- Labrador Retriever
- Golden Retriever
- Chesapeake Retriever.

These dogs are great swimmers and enjoy retrieving birds from water.

**4. Scenting and tracking:** Beagles, Foxhounds and Bloodhounds are breeds of scent hounds. They use their nose to scent, track and find prey.

Deer, for example, can inhabit thick bush and are masters of concealing themselves. Many hunters have walked by deer hiding in thick cover, simply because the hunter could not see it. This is where a dog can be advantageous. When a dog catches a scent, it will remain motionless and point or crouch towards the direction of the deer. This gives the hunter time to carefully scan the bush and locate the animal before it slips away.

After taking a shot, sometimes the animal cannot be easily found. Ethical hunters will make every effort to recover the animal or apply a finishing shot.

Dogs can be of great assistance due to their increased sense of sight and smell and can locate these animals quickly and more efficiently.

Hounds can also be trained to run the animal in the direction of hunters staged at certain locations.

This technique works well for smaller game found in thick cover or areas that a hunter cannot walk through. Hounds are very energetic, sociable and prefer to hunt in groups, although they are just as well-equipped to hunt on their own.

## Pig hunting dogs

While purebred gundogs are popular, many keen pig hunters will use cross breeds, as they can exhibit the most desirable traits from a variety of breeds. Popular breed groups include:

- Terriers
- Hounds
- Pointers
- Kelpies
- Collies
- Heelers
- Bull Arabs.



Pig dogs, when hunting in a team or on their own, must be able to execute three specific tasks to successfully capture wild pigs:

**1. Finding:** Finding dogs must have the ability to find a pig by scent. Some dogs can find pig scent from the back of a vehicle, while other dogs will search the bush until the scent is caught.

Depending on the terrain and its accessibility, hunters may prefer short-range finders that will only track fresh scent or long range finders that will track cold scent for many kilometres.

**2. Bailing:** These dogs are generally a smart-working breed with high stamina and great athletic ability to manoeuvre through the scrub and withstand hot environments. Bailing dogs are used to chase, stop and bail a pig until the hunter or other dogs arrive.

**3. Holding:** Holding dogs will chase, stop and hold a pig until the hunter arrives to dispatch it quickly and ethically. These dogs must have great strength and resilience and wide, strong jaws to be able to maintain a reliable grip.

It is important that a holding dog only applies enough force to prevent the pig from escaping and must not kill or injure the pig. An experienced holder may decide to bail the pig if it cannot be handled alone or if the hunter takes too long to arrive.

## Mustering dogs

Dogs used for mustering goats are typically all-round working dogs with strong herding ability. With the right capabilities, any dog can be used to muster goats, however the most common breeds generally include:



- Kelpie
- Border Collie
- Koolie
- Cattle Dog
- Australian Shepherd.

A successful goat mustering dog should have the following traits:

1. A strong natural instinct to work goats.
2. Can be sent around a mob of goats and bring them back without losing any or allowing the mob to drift off line.
3. Can drive or move the mob of goats away from the handler.
4. Ability to use the right amount of 'eye' to control the goats.
5. Ability to move (push) the goats in a certain direction, particularly when getting them into yards.
6. Ability to cover and prevent the goats from running past them.
7. Can hold the goats in one area.
8. Barks on command.
9. Works well in the open and in the yard.

## Basic training methods

All hunting dogs must be well-trained, obedient and balanced. A well-trained hunting dog will ensure that every hunt is not only successful but also safe, ethical and legal. A responsible hunter's dog should consistently respond to basic commands:



- sit
- stay
- come
- drop
- leave it.

It is important to begin training your hunting dog while it is a puppy. Proper training and socialising your dog with others while young is fundamental to developing an effective hunting companion.



### Positive reinforcement training method

Dogs learn when being rewarded for good behaviour. Teaching your dog to perform an action or behaviour in order to gain a reward is known as positive reinforcement. The reward must be something your dog enjoys, such as a pat, verbal praise, a chew toy or most commonly a treat. This is the most basic form of positive reinforcement training and effectively communicates to your dog that they displayed the correct behaviour.

Only reward your dog for correct behaviours and ignore unwanted behaviours. Dogs are pack

animals and respond to their leader. The reward demonstrates your leadership without using punishment.

A properly trained hunting dog must:

- be stock proofed and show no interest in any other animal apart from the target animals
- be socialised with other dogs and people of all ages and sizes
- be easily controlled at all times.

If a dog displays anti-social, aggressive or undesirable behaviour, it should not be used for hunting.

Never strike your dog for doing the wrong thing. One simple act of punishment may be impossible to rectify.



### Socialising your hunting dog

Socialising should begin at the puppy stage to prevent unwanted behavioural problems. Socialising becomes more important at six months of age and should be continued throughout your dog's life.

Lack of social interactions can lead to aggression, shyness and hyperactivity. Hunters should

regularly expose their dogs to the social situations they need them to cope with, such as hunting with other dogs, travelling in a vehicle and gunfire.

Socialising can sometimes become overwhelming for some dogs, so remember to keep the sessions short and enjoyable.



### Hunting deer with dogs

Hunting deer with dogs is a very effective method of locating deer in thick and dense terrain. The hunter may not see the deer; however, the dog will locate it using their highly developed senses of sight, sound and smell. Once the dog points a deer, the hunter has time to find the animal and prepare to take the shot.

As with all types of hunting, animal welfare practices must always be observed.



### Hunting game birds with dogs

Hunting native game birds with the assistance of a gundog is a permitted hunting method under the Native Game Bird Management Program in NSW. Other non-indigenous game birds covered by the *Game and Feral Animal Control Act 2002* may also be hunted with a gundog.

Many properties that take part in the Native Game Bird Management Program grow rice crops. Generally, the rice crops are irrigated with water and are impacted by ducks each year. When ducks are harvested, it is best practice to recover them quickly before other birds can be targeted. The best way to retrieve the birds and cause minimal damage to the rice crop is with the use of highly trained gundogs. All gundogs are predisposed to retrieving harvested game, regardless of their breed.



When hunting native game birds under the program, you may only use a dog to:

- locate
- flush
- point
- retrieve.



Dogs may also be used in game bird field trials that are conducted by an approved hunting club or organisation on private land.

### Hunting pigs with dogs

Using dogs to hunt pigs is an extremely effective method of reducing feral pig populations that have become conditioned to baiting, shooting and trapping programs. These animals respond by living in thick terrain and often become nocturnal.



As with all types of hunting, animal welfare must be the primary consideration when hunting pigs with dogs. This method of hunting increases welfare considerations for both the pigs and the hunting dogs.

---

Important – Any dog that is overly aggressive should never be used for hunting.

---

### Mustering goats with dogs

Mustering wild goats in difficult terrain and in thick vegetation is extremely challenging. For a dog to become successful at mustering goats it must first know how to work livestock such as sheep and cattle.

These dogs must:

- be intelligent
- be well trained
- understand handlers herding commands
- be able to work with minimal supervision at a distance
- not be aggressive or bite.

It's recommended that young and inexperienced dogs are not used to muster goats as they can be easily injured, become overwhelmed and end up chasing the goats instead of mustering them.



### Other legislation

Mustering, loading, transporting, unloading, holding and slaughtering of feral goats must be done with the minimum amount of stress, pain or suffering and follow all relevant National and NSW legislation. In addition to hunting licence rules and regulations, guidelines and legislation for other procedures can be found in:

- the National Livestock Identification Scheme (NLIS)
- Prevention of Cruelty to Animals Act 1979
- Australian Standards and Guidelines for the Welfare of Animals – Land Transport of Livestock (AHA 2008)
- Pest Smart – standard operating procedure 'Mustering of feral goats' GOA003.



## HUNTING ON PUBLIC AND PRIVATE LANDS



### Using your dog when hunting on public land

The *Game and Feral Animal Control Act 2002* and its Regulation 2022 regulates the use of hunting dogs. All dogs used for hunting must be listed on your Written Permission.

All hunters must comply by the following licence conditions.

#### Gundog rules

When hunting native game birds or small game animals such as rabbits and foxes, you may only use a dog to:

- locate
- flush
- point
- retrieve.

When hunting deer using dogs, hunters must:

- only use the dog(s) for locating, pointing or flushing deer
- not use more than 1 dog if hunting alone

- not use more than 2 dogs if hunting as part of a group.

#### Pig dog rules

When hunting pigs using dogs on public land, you must:

- only use the dog(s) for locating, holding and bailing pigs
- ensure that the dog does not chase any other species of animal
- not use more than 3 dogs when hunting alone
- not use more than 5 dogs when hunting as part of a group
- not leave or abandon the dog on public land.



### Booking a hunt with your dogs

When you book a written permission to hunt on public land in NSW, you must include some specific information about the dogs that will be hunting with you.

You will be asked to provide the following details:

- the breed of your dog(s)
- the sex of your dog(s)
- the colour of your dog(s)
- the microchip number of your dog(s).

REGISTRATION	VEHICLE MAKE	MODEL	COLOUR	BODY TYPE	
ABC123	Ford	Ranger	Black	Single Cab - Ute/Tub Back	Remove

Dog Details		Add Dog
No dogs recorded		
New Dog		
Name *	<input type="text" value="Rover"/>	Breed *
		<input type="text" value="Bull Arab"/>
Sex *	<input type="text" value="Male"/>	Colour *
		<input type="text" value="Brown &amp; White"/>
Microchip Number *	<input type="text" value="94500000123456"/>	
<input type="button" value="Add this dog"/>		<input type="button" value="Cancel"/>
<input type="button" value="Submit"/>		<input type="button" value="Back"/>

Any dogs being used to hunt on public land must:

- be registered and microchipped
- be wearing a collar with a metal tag securely attached, showing the name, address and telephone number of the dogs registered owner
- be wearing a radio tracking collar or be on a lead
- be tied up, caged or otherwise restrained while travelling in a vehicle
- not leave the vehicle until it has come to a complete stop.



## Radio tracking collars

Radio tracking collars are mandatory for all free-ranging dogs that are hunting on public land and are used to track your dog's location when they are actively hunting. Radio tracking collars will prevent your dog from becoming lost and can also help the hunter locate and dispatch captured pigs as quickly as possible.

It is also recommended that radio tracking collars are used when hunting with dogs on private land.

Make sure your tracking collar complies with current Australian Radiofrequency Spectrum plan.

## Hunting pigs with dogs at night

The NSW Public Land Hunting Program allows hunting pigs with dogs in most State forests. Hunting pigs with dogs at night is also permitted in some of those forests under specific conditions.

Hunters must be aware of the additional risks, safety measures and hunting conditions put in place for when hunting at night.

When hunting pigs with dogs at night, hunters must:

- only hunt with a dog during night-time if 'dogs (night-time)' is specified as an available hunting method on your written permission
- attach a form of illumination to each free-ranging hunting dog
- not use any spot or search light from a moving vehicle when hunting at night
- understand that firearms and bows are not permitted to be used when hunting with dogs at night; firearms and bows must be locked away and not readily accessible at times when you are hunting with dogs at night.





Remember that you cannot hunt at night on public land and unless the forest has been designated as a night-time pig dog hunting forest and you hold a valid written permission.

### Respect the landowner

Before you enter any private land, make sure you have the landowner's or manager's permission and always ask for permission to hunt with dogs.

All animal welfare laws remain in effect when hunting pigs with dogs on private land, and no unnecessary pain or suffering should be inflicted on hunted pigs.

Hunters must always know the property boundaries and must not allow their dogs to cross onto land they don't have permission to be on.

Trespassing on land that you do not have permission to hunt on is a criminal offence and will result in harsh penalties. The following penalties may apply to anyone in breach of trespass laws:

- penalty infringement notices
- seizure and possible confiscation of hunting-related equipment including firearms and vehicles
- court attendance — if convicted, you may face significant fines, court orders and even imprisonment.



### Pig dog hunting equipment

A dedicated hunter understands the importance of safety during the hunt. Dogs can sometimes become injured when crossing fences, jumping from the vehicle or from finding, bailing and holding pigs. Therefore, hunters must take all necessary steps to ensure the safety of their dogs.

The following protective items are strongly recommended to keep your pig dog safe during the hunt.



### Chest plates and neck collars

Chest plates and neck collars are essential in protecting your dog against injuries caused by a pig. They are designed to cover the dog's vital areas while allowing your dog to still move freely. Some plates and collars include a pocket to attach a form of illumination and a metal tag that must be engraved with the registered owners' details. They must also allow for the use of a radio tracking collar.

Hunters must carefully select the most appropriate fit and type of chest plate or collar. Dogs wearing a full chest plate will tire and overheat more quickly, so the hunter must limit the length of the chase and must also provide fresh drinking water and a cool place for the dog to rest after the hunt.



### Leads

If your dog is not wearing a radio tracking collar, it must always be attached to a lead. The lead must be made of a high strength material that will not tear and must also have a strong metal clip.

Dogs that are on a lead must wear a collar with a name tag attached that shows the dog's name and the address and telephone number of its registered owner.

### Welfare of hunted pigs

Hunters have a duty of care, are bound by laws and are responsible for ensuring acceptable standards of animal welfare are practiced during the hunt. Pigs must be dispatched quickly and efficiently, with full regard for their welfare.

It is recommended that pigs are found and bailed, and holding should be avoided where possible.

If a captured pig must be held, it should be for the shortest amount of time possible. Prolonged holding can cause severe stress and pain to the pig and may contravene requirements set out in the *Prevention of Cruelty to Animals Act 1979*. It can also cause injury to the dogs.



### *Prevention of Cruelty to Animals Act 1979*

The *Prevention of Cruelty to Animal Act 1979* legally obligates all hunters to ensure that no unnecessary pain is inflicted on a hunted animal. Responsible and humane hunting helps to maintain community confidence in your activity, so it may be continued into the future.

It is an offence to hunt pigs with dogs in a way that results in unnecessary pain or suffering for either the pigs or the dogs.

An example of an offence is when an excessive number of dogs are used or if the dogs are set upon a pig that is already in a situation where it can be quickly dispatched.

Revisit Unit 2 of Section 1: Hunting laws in NSW for more information about this Act.

---

Important – To set a dog onto a pig with the intention of mauling or killing it is an offence that carries heavy penalties.

---

## Humane dispatch

Large boars can be very difficult to dispatch, due to the thick hide protecting their shoulder called a shield. This can be up to 100 millimetres thick and is extremely tough. The vital area of the chest and organ placement is also lower and more forward than most other game species.

Pigs can be humanely dispatched by the following methods:

### The hold stick method

A specialised knife called a pig sticker is designed to penetrate the chest cavity and pierce the heart, veins and arteries. The blade should be razor-sharp, single-sided, at least 170 millimetres in length and feature a non-slip handle.

The knife is aimed at the heart and enters the chest cavity either through the armpit or through the front of the chest, just above the sternum. A swift single stab into the heart is all that's required to ensure a quick and humane death.

## Using a firearm

This method is mostly used when a pig is bailed up and standing its ground. The dogs should remain a safe distance from the pig, allowing the hunter to make a clean, close range shot to the head vital zone.

A firearm may be the preferred method if the pig is being held, and there is a risk of injury to the dogs, the hunter or the pig itself.

The hunter must exercise every caution when using a firearm at close range.

Before taking the shot, a hunter must be aware of the:

- location of the dog(s)
- muzzle blast from the firearm
- ricochet from the projectile
- safe backstop should the projectile exit the pig.



---

Important – When hunting on public land at night, the use of firearms is strictly prohibited.

---



## WELFARE OF YOUR HUNTING DOG

### Travelling with your hunting dog

Hunting often requires travelling long distances into rural areas. When travelling with your dog, you must ensure that they are safe and comfortable. Most dogs are transported in metal dog crates on the back of a utility or inside the rear canopy.

If transporting your dog in a crate, it is important that your dog has enough room to move around safely and has sufficient shade and shelter.



The biggest welfare risks associated with crate transport are heat exhaustion and dehydration from the confined space and metal surfaces.

When travelling with your dog, you should:

- avoid feeding your dog immediately before you travel in order to avoid upset stomachs
- provide comfortable bedding
- take breaks every two hours
- provide fresh water and bathroom time during each break
- ensure your dog has protection from the cold,

heat, rain and inhaling dust and fumes

- provide adequate ventilation if they are being transported in an enclosed section of the vehicle
- never leave them unrestrained on the back of the vehicle.

### What to do if your dog is injured

Knowing how to administer canine first aid is an essential skill all gundog owners should know. Common medical issues dog owners should be on alert for include:

#### Skin lacerations

Skin lacerations are the most common injuries to a hunting dog. Most cuts can be treated in the field using a simple canine first-aid kit. More serious cuts that cause pain or prevent your dog from moving about freely require an urgent trip to the vet.

#### Shock

Urgent medical treatment is required if your dog goes into shock, and recognising the early warning signs may help you save the dog's life.

Shock can occur for many reasons, commonly from pain, trauma, reaction to a bite or from fluid loss. It is the response to a loss of circulation.

Early warning signs of shock can be:

- increased heart rate
- low temperature
- pale or blue gums
- weakness or lethargy
- slow and shallow breathing
- inability to focus or unusual staring.



You must seek urgent medical advice if you recognise any of these signs. Keep the dog clam and warm, and apply gentle massage to the legs to maintain circulation.

### Overheating and dehydration

Dogs are prone to overheating and dehydration, known as hyperthermia. It is important that you immediately stop hunting and provide your dog with fresh drinking water and a cool place to rest when they show symptoms.

### Hypothermia

If your dog is wet and begins to shiver, they may be experiencing hypothermia and must be dried and warmed up immediately.



### Snake bites

If you suspect your dog has been bitten by a snake, you should:

- try to identify the snake species
- keep the dog calm and quiet
- limit its movements
- apply pressure to the bite
- seek urgent veterinary treatment.

Do not try to catch or kill the snake. Snakes are protected, and killing them is illegal.

---

Hunter's tip – It's a requirement under PoCTA (Prevention of Cruelty to Animals Act) that all hunting dogs must receive veterinary treatment if injured.

---

## 1080 baits – how to avoid poisoning and what to do

Pest animals pose a major threat to native wildlife, agriculture and forestry. Targeted baiting programs using Sodium fluoroacetate, known as 1080, is commonly used by agencies such as Local Land Services and Forestry Corporation of NSW (FCNSW) for controlling populations of wild dogs and foxes on many public lands.

These land managers and pest management agencies strategically manage these ground and aerial baiting programs to ensure populations are managed to limit negative impacts.



A baiting program may be scheduled at short notice. When this happens, hunters who hold a written permission for affected forests will receive an SMS or an email notification from DPI Hunting, requesting a reprint of the written permission with the added advisory.

At times a baiting program will not be marked on a map and you may not receive a DPI advisory. In this instance you must comply with all baiting signage.

While the baited area will remain open to hunting,

it is your responsibility to be vigilant when hunting in areas where baiting programs are conducted and act immediately if you observe or suspect your dog has eaten a 1080 bait. You must stop hunting and contact your vet immediately.

You should always:

- avoid hunting in areas with a dog that has been heavily baited with 1080 such as ridgelines where aerial application of 1080 meat baits
- muzzle your dog if hunting in an area where 1080 baits are being used
- ask the landowner or manager if any 1080 baiting programs are being undertaken on their property
- read your written permission and hunting maps for 1080 baiting notifications when you are hunting on public land
- always be on the lookout for 1080 signage and avoid hunting in those areas
- keep a close watch on your dog and prevent them from eating any unknown items on the ground
- train your dogs to be bait adverse, and only eat on command
- be prepared and contact your vet immediately for advice on the best practice to induce vomiting if your dog consumes a bait
- download the most current DPI forest hunting maps to locate aerial bait lines that should be avoided.

Notices on current 1080 baiting programs taking place can be viewed on the FCNSW website. FCNSW places signposts at the main entrances for the forests that are being actively baited.

### END OF SECTION 2, CATEGORY 3: HUNTING WITH DOGS

---

Hunter's tip – Hunters must not interfere with any 1080 baits or equipment when hunting on public land.

---

